

Requirements for AC/DC converter stations, DC switching stations, Power Park Modules and DC Grid controller offline models, SIL models and C&P cubicles

ABOUT INTEROPERA:

The InterOPERA project will define technical frameworks and standards for electricity transmission and accelerate the integration of renewable energy. Ensuring that HVDC systems, HVDC transmission systems or HVDC components from different suppliers can work together – making them “interoperable”- is a top priority to accelerate Europe’s energy transition.



**Co-funded by
the European Union**

DISCLAIMER:

Co-funded by the European Union. Views and opinions expressed are however those of the author(s) only and do not necessarily reflect those of the European Union or CINEA. Neither the European Union nor the granting authority can be held responsible for them.

PROJECT DETAILS:

Duration: 1 January 2023 – 30 April 2027

Grant agreement: 101095874

Requirements for AC/DC converter stations, DC switching stations, Power Park modules and DC Grid controller offline models, SIL models and C&P cubicles

DELIVERABLE D1.1

MARCH 2025

AUTHORS:

Alexandra BONNET, RTE
Reza BAKHSHI-JAFARABADI, TU Delft
Marjan POPOV, TU Delft
Farzad DEGHAN MARVASTI, TU Delft
Aleksandra LEKIC, TU Delft
Remko KOORNNEEF, TU Delft
Arcadio PERRILLA, TenneT
Laurent CHEDOT, SuperGrid Institute
Andreas SACIAK, 50Hertz

REVIEWERS:

Sébastien DENNETIERE, RTE
Holger SCHULDT, Siemens Energy
Nico KLÖTZL, TenneT
Robert DIMITROVSKI, TenneT
Klaus VENNEMAN, Amprion
Mickaël THIBERT, RTE
Sebastian HARANT, Siemens Energy
Nemanja KRAJISNIK, Siemens Energy
Boumedyen NEDJAR, Siemens Gamesa
Yicheng LIAO, Energinet
Emmanuel AMANKWAH, GE Vernova
Hamidreza MIRTAHERI, Vestas Wind Systems
Mehmet Sertug BASAR, Vestas Wind Systems
João Pedro AYRES PEREIRA DA CUNHA RAMOS, Vestas Wind Systems
Christian WIKSTROM, Hitachi Energy
Bence HÁTSÁGI, SCiBreak

VERSION CONTROL

Version number	V1
Created by	T1.2 Group
Date created	19/12/2023
Version number	V2
Created by	T1.2 Group
Date created	04/07/2024
Version number	V2.1
Modified by	T1.2 Group
Date modified	09/01/2024
Status	Final
Data Classification	Public

Table of Contents

Executive summary	7
Context	9
1 Requirements for offline models	11
1.1 Requirements applicable to all vendors	11
1.1.1 Type of studies, frequency and operating range validity	11
1.1.2 Requirements on model format and performance	14
1.1.3 Documentation	25
1.1.4 Maintainability and updates	26
1.2 Requirements for offline models – specific to DC grid controller	28
1.3 Requirements for offline models – specific to HVDC converter station	29
1.3.1 Structure and content of models	29
1.3.2 Model performance	31
1.3.3 Parameter and data accessibility for control	32
1.3.4 Signals	33
1.4 Requirements for offline models – specific to PPM	35
1.4.1 Structure and content of models	35
1.4.2 Model performance	38
1.4.3 Signals	38
1.5 Requirements for offline models – specific to DC switching station	40
1.5.1 Structure and content of models	40
1.5.2 Model performance	41
1.5.3 Signals	42
2 Requirements for hardware and software in the loop	43
2.1 Requirements applicable to all vendors	43
2.1.1 Typical layout for the real-time simulation platform	43
2.1.2 Preparation of the replica	45
2.1.3 Internal tests at vendor’s lab and Factory System Tests preparation	60

2.1.4 System integrator’s training	62
2.1.5 Factory System Tests at vendor’s lab.....	63
2.1.6 Delivery and installation of the system at the real-time lab facility, lab constraints and EHS	64
2.1.7 Commissioning of delivered cubicles at the real-time lab facility	65
2.1.8 After the commissioning	67
2.2 Requirements for hardware and software in the loop – specific to DC grid controller and communication system	71
2.2.1 Communication system.....	71
2.2.2 Signals for analysis	71
2.2.3 Control system solution.....	72
2.2.4 Automatic testing functionality	72
2.3 Requirements for hardware in the loop – specific to DC Switching station	76
2.3.1 Control and protection required functions	76
2.3.2 Internal signals to be accessible and recorded	76
2.4 Requirements for hardware in the loop – specific to PPM.....	77
2.4.1 Control and protection required functions	77
2.4.2 Simulation of the WT behavior	80
2.4.3 Internal signals to be accessible and recorded	80
2.5 Requirements for hardware in the loop – specific to HVDC converter station	82
2.5.1 Control and protection required functions	82
2.5.2 Converter valve model	82
2.5.3 Quick restart option	84
2.5.4 Internal signals to be accessible and recorded	84
Abbreviations, Acronyms and Definition	85
Annex 1.....	87
References	88

Executive summary

In multi-vendor and multi-terminal HVDC projects, interaction studies are the key to ensure a safe and reliable operation of the AC and DC transmission systems. In InterOPERA project, as part of the work package 1 (WP1), the task 1.1 aims at defining the minimum requirements for the provision of models and real-time systems to perform these interaction studies, limited to Electro-magnetic transient (EMT). This set of requirements constitutes the deliverable D1.1, which is the goal of this document.

The requirements are divided into two main parts:

- The requirements for offline models that will be used for offline studies
- The requirements for real-time systems, such as Hardware in the loop (HIL) and Software in the loop (SIL¹), that will be used for real-time studies.

Most of the requirements are generic and applicable to any subsystem² (power park modules, HVDC converter stations, etc.). But sometimes, more attention must be given on a case-by-case basis due to the particularities of each subsystem. Therefore, the generic requirements are completed by specific requirements for each subsystem.

This set of requirements aims to be used for real project as well as for InterOPERA. However, there can be some differences between real projects and InterOPERA due to different context. On one hand, additional requirements only applicable to InterOPERA have been written. For easier identification, these additional requirements are written *in light blue and Italic*. On the other hand, it is worth pointing out that this deliverable is about the minimum requirements. But some TSOs are thinking of getting deeper involved for commercial project, by comparison to InterOPERA. In that case, the impact on the requirements shall be assessed: what supplementary requirements shall be defined in commercial projects, compared to InterOPERA, depending on the contractual context? To lay the foundation for commercial projects, *in light brown*, additional information is given to better understand the reasons for the requirements, the current limitations, the possible future enhancements, and how to adapt the requirements to commercial projects.

For this deliverable, three versions are expected:

- for the vendors to know what to provide for the template models and C&P cubicles during phase 1³ of InterOPERA, a first and early release of deliverable D1.1 has been prepared. This release was accessible by InterOPERA partners only.
- Building on the first version, a second version of this deliverable has been prepared, considering inputs from other InterOPERA work packages and from the stakeholder committee. This

¹ In InterOPERA, SIL is used only for real-time, for the real code running on a hardware that is not the exact hardware used at site (or state-of-the-art one for InterOPERA). This hardware can be a processor operating in real-time, a Field Programmable Gate Arrays circuit, etc.

² See [11] for the definition of "subsystem".

³ During phase 1 of InterOPERA (2023-2024), dry-run tests will be performed to check:

- the consistency of the requirements written in this document,
- the capability of the vendors to provide models and replicas fulfilling these requirements,
- the usability of these models and replicas by the system integrator.

version – which is the current document - will be used as a reference for the models and replicas that should be delivered for phase 2⁴ and constitutes the official deliverable to be published.

- At last, a third version is expected, with refined requirements based on the lessons learnt during the dry-run and during phase 2 interaction studies.

Finally, in InterOPERA, the use of the control and protection cubicles is limited to InterOPERA project duration and their ownership remains to the vendors during the execution time of the project. Consequently, requirements for long-term maintenance of the control and protection cubicles are not considered for InterOPERA but shall be discussed for commercial projects.

The requirements are numbered for easier identification.

⁴ During phase 2 of InterOPERA, interactions studies will be performed to check:

- the relevance of the functional requirements defined in InterOPERA,
- the capability of the vendors to provide systems fulfilling these functional requirements.

Context

For any project connected to the transmission grid, interaction studies are crucial to ensure the safe and reliable operation of the transmission system. These interaction studies do not cease after the site acceptance tests but continue throughout the entire operational use of the system.

During this operational phase, a significant portion of the simulation studies is conducted as an integral part of power system operations. This includes identifying how the system responds to the changes of the operating conditions, and how the system potentially impacts changes to the connected system structure as part of power system planning. Simulations are also useful for post-event analysis. Simulations can help recreate an event in which a particular contingency took place to determine the cause and suggest mitigation solutions. Simulations are also valuable for conducting pre-specification and specification studies for new transmission or generation equipment or for refurbishment projects.

This is why it is currently common practice to provide models for EMT studies and, to a more limited extent, replicas for real-time simulations. However, presently available models and replicas encounters certain limitations. They are tailored for use by only a few stakeholders, generally the vendor itself⁵ and the transmission system owner/operator, within the context of a well-known AC transmission system with a slowly evolving grid.

In the context of the current rapid development of the grid, with the extensive integration of renewables such as offshore wind turbines, the proliferation of point-to-point HVDC links, and the need to establish multi-vendor and multi-terminal HVDC grids, the aforementioned limitations must be addressed.

Indeed, the need to perform studies decades after the initial commissioning will increase. It can be studies for:

- Designing extension of the grid: parties in charge of extension of the grid shall be able to get an accurate representation of the dynamic behavior of the existing system.
- Supporting adjustments in the topology on the DC side.
- Performing post event analysis (misoperation of the converter and/or interaction with the surrounding grid).
- Studying replacement of electrical equipment in the converter station or in a close vicinity.

All these actions should be feasible with the collected models without necessitating requests to all vendors for new model supplies. Therefore, the primary challenge of these requirements is to ensure that the solution provided by the vendors will be readily accessible, operational, and usable over an extended period in line with the entire life expectancy of the corresponding system.

During this timeframe, simulation tools and their versions will undergo changes. For instance, the continual use of outdated software versions is also not viable for IT security reasons and due to operating system dependencies. Consequently, offline black-box models must be independent of the specific EMT simulation tools. Similarly, real-time simulators can break down and need to be replaced. For that purpose, interfaces of control and protection cubicles with real-time simulators shall have non-proprietary and clearly documented interfaces. Furthermore, these compatible interfaces should be

⁵ Vendors are listed here because they use the models, but generally they don't built replicas for their own

thoroughly documented to facilitate the connection of models and replicas to other EMT simulation tools.

The second primary justification for tool independence is the requirement to conduct studies on one simulation tool at a time, incorporating all the models or real-time systems connected to the same circuit. This consideration arises in the context of multi-vendor and multi-terminal HVDC grids, where multiple parties may be involved simultaneously, including various vendors, wind park developers, and TSOs. Furthermore, these stakeholders may not necessarily utilize the same tool simultaneously. To illustrate and validate the performance of requirements and the successful achievement of the tool-independence objective, InterOPERA will utilize two EMT offline simulation tools (PSCAD and EMTP) and two real-time simulation tools (RTDS and HYPERSIM).

To facilitate the implementation of multi-vendor and multi-terminal HVDC projects, new subsystems are introduced: the *DC switching station* and the *DC Grid controller*. The second major challenge regarding the following requirements is to incorporate these new components into the interaction studies and to adjust the existing components' specifications to accommodate the innovations introduced by the new components. Specifically, the DC Grid controller establishes a novel layer of communication between the DC Grid controller and all subsystems.

The third and final, yet equally important, main challenge presented by this set of requirements is to strike a delicate balance between the necessity for accessing information to conduct the studies and the protection of intellectual property, considering strong vendor support. This set of requirements is drafted in a manner that ensures the provision of information, models, software in the loop, and cubicles without infringing upon manufacturers' intellectual property, while facilitating effective interaction studies. Nonetheless, it is worth pointing out that this document is limited to the technical requirements but legal aspects, for example the need for Non-Disclosure Agreement, shall also be considered when delivering information, models, etc. and is discussed in another work package of InterOPERA (WP4).

Lastly, the adopted stance for this set of requirements is to specify functionalities only, minimize the set of requirements, and hold the vendors accountable for meeting these functional requirements with their own solution.

1 Requirements for offline models

1.1 Requirements applicable to all vendors

1.1.1 Type of studies, frequency and operating range validity

OFFLINE 1.

Current requirement

With the model provided, it shall be possible to perform the following tests, aiming at de-risking the operation of the system⁶ *within the limit of the functions agreed in WP2 and the frame of the demonstrator defined in WP3*:

- Energization – De-energization⁷ of the grid and all its components, *with the different scenarios defined in WP3*:
 - Power Park Module (PPM)
 - Converter station (from AC side and from DC side)
 - AC and DC lines
 - AC and DC cables
 - Power transformer
 - Busbar
 - Mechanically switched reactors and capacitors (or AC filters)

- Tests to verify the behavior of the system in case of transients due to temporary or permanent, balanced or unbalanced AC or DC faults or due to an unexpected trip of a circuit breaker:
 - Protection coordination between all parties
 - AC protection
 - DC protection (*to be noted that no test of DC fault detection algorithm is currently expected in InterOPERA, this is under discussion in WP2*)
 - Trip case: robustness of the remaining grid, recovery/reconfiguration process
 - No trip case: correct behavior of the system during the fault and good recovery after fault clearing
 - AC Fault Ride Through (FRT) capability
 - DC FRT capability

⁶ The risks to be analyzed in this context are related to potential adverse interactions (electromagnetic interactions, control interactions with near-by power electronic device, etc.)

⁷ “energization” and “de-energization” expressions are used when the real sequences are replaced by an equivalent solution to meet the specific constraints of offline simulations. More information is available in InterOPERA D1.3 document.

The location of faults within the provision of each vendor is defined in the specific requirements. Protection coordination within each sub-system of a given vendor is not part of the interaction studies, only protection coordination between stations⁸ provided by several vendors is expected.

- Dynamic performance studies: all the control functions involved directly or indirectly in active power and reactive power management are tested to check their performance and identify potential interactions and mitigation solutions for the identified negative interactions. For example⁹:
 - Active / reactive power ramping
 - Frequency and voltage control
 - Load rejection
 - Emergency Power Control functionalities
 - ...
- AC offshore and/or onshore grid forming capability studies
- AC onshore grid black start scenario studies (*it is worth pointing out that no AC onshore grid black start scenario is currently expected in InterOPERA*)
- Transient studies due to AC or DC switching off- and on operation, activation of DC breakers, converter blocking phenomenon, slow-front transient overvoltage¹⁰ and temporary overvoltage
- Sub-synchronous interaction studies
- Harmonic stability studies: assessment of frequency dependent impedance of the system at the connection points (magnitude and phase angle of the $Z(f)$) in the frequency range that the model is valid and test of mitigation techniques.
- Other stability studies¹¹
- Performance of the DC grid controller for all above studies.
- Impact of the loss of telecommunication on the studies

Justification

This is based on the list of studies commonly performed. Few items have been added to consider the new opportunities offered by multi-terminal multi-vendor HVDC grids: DC protection, DC Fault Ride Through, DC Grid controller performance.

After review of the advantages and disadvantages, it has been decided to not request for eigenvalue analysis in InterOPERA. Therefore, it has not been written as part of the list. Nonetheless, eigenvalue analysis is currently under discussion in InterOPERA deliverable D1.3.

⁸ Definition of "station" mentioned in WP2, D2.1 applies.

⁹ These examples shall be defined more precisely in WP2 and WP3. This document does not presume of their definitions.

¹⁰ This is limited to slow-front transient overvoltages that are slow enough to be consistent with the requested time steps.

¹¹ These other stability studies will be defined in D1.3 if any.

How to use this requirement for real projects

This list must be adapted to the projects. For example, if no DC FRT capability is defined for a project, this can be removed from the list. This comment is also true for InterOPERA, for two reasons:

- this list has been written before all the functional requirements have been written in the other WPs.
- It is expected in InterOPERA to focus more on the new types of interactions. Therefore, even if sub-synchronous interaction studies are listed here and can theoretically be performed in InterOPERA, sub-synchronous torsional interaction will most probably not be part of InterOPERA studies to prioritize the work on other studies.

Maturity level

The current requirement can evolve during InterOPERA for the following reasons:

- Deliverable D1.3 will show if more studies are necessary and will give more details on the studies. Finally, this requirement will have to be updated as per D1.3 results.
- The current document might have to be completed to give precise requirements for the provision:
 - o of an AC and DC impedance-based model, see also comment in OFFLINE 2 (for example, a standard scanning method with a universal time step and recording resolution would have to be specified if a frequency scan is used, or another solution should be defined if a frequency scan can't be used)
 - o of state-space models.

OFFLINE 2.

Current requirement

The model shall be valid at least in the frequency range 0.2Hz to 2.5 kHz for relevant studies. The validity of the model shall be ensured for the given frequency range at all the connection points.

Justification

Only EMT is considered here. Harmonic impedance model, as defined in [7] and RMS model are not required and specified for InterOPERA. Consequently, in InterOPERA, if necessary, time-domain model will be used by the system integrator to calculate the harmonic impedance model in the frequency domain.

Nonetheless, even if the provision of such model is not mandatory in InterOPERA as per consortium proposal, having it for the wind turbine could be helpful for aggregation validation by the system integrator. Therefore, in the interest of the project, if possible, it is proposed that the wind turbine vendors share the harmonic impedance model in InterOPERA for the wind turbine model to be used, as this is usually done on commercial projects.

The 2.5 kHz requirement comes from [1]. This frequency is a compromise between:

- The risk of having adverse interactions and the anticipated consequences. For example, in [1], the threshold of 2.5 kHz has been chosen because it has been noticed on some examples that interactions up to that frequency level could happen.
- The need of performing interaction studies in a reasonable amount of time. Having models valid on higher frequency ranges would require performing the studies with smaller time steps and would require models including additional phenomena. Both aspects would significantly slow down the studies. Hence, generally, for higher frequency ranges, other models and solutions are used and specific studies are performed.

Maturity level

By having the time-domain model that is limited to 2.5 kHz, it is not possible to use it to obtain the harmonic impedance model up to 9 kHz. This is a limitation compared to [1], which offers the possibility to the TSOs to request for a harmonic impedance model valid up to 9 kHz. Therefore, work will be achieved during InterOPERA on this topic, to path the way to this target. Current requirement might then be completed to request for a harmonic impedance model, with a specific frequency range.

One can note that the maturity level of harmonic impedance model is not the same between all type of vendors: providing the harmonic impedance model is more common for wind turbines compared to HVDC converter station, as it is useful to get more accurate aggregation results.

OFFLINE 3.

Current requirement

The model shall be provided with sufficient accuracy for the purpose of the tests, for the specified operating range and all operating modes of the system, *as defined in WP2 and WP3*, in positive, negative and zero phase sequences.

Justification

This requirement comes from [1]. Additionally, zero phase sequence has been added.

OFFLINE 4.

For InterOPERA context, vendor shall consider all the topologies decided in WP3 and shall adapt its provision accordingly. It can be one configurable model, or as many models as topologies.

1.1.2 Requirements on model format and performance

To introduce this chapter, the main principle of the separation between electrical component representation and C&P representation in EMT model is illustrated in Figure 1.

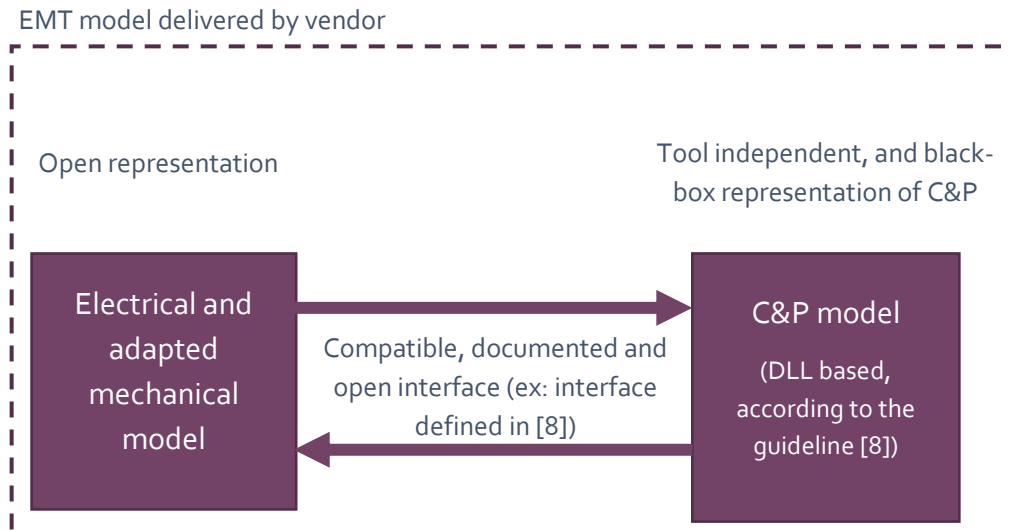

Figure 1 – Main principle of the separation between electrical component representation and C&P representation.

OFFLINE 5.

Current requirement

When delivering a model, each subsystem¹² shall be represented as one block at the first level of access in the EMT tool, except the Energy dissipation device, which can be included in the switching station model or in the converter station model, and except otherwise stated in the specific subsystem requirements.

1.1.2.1 Requirements on electrical and adapted mechanical device modelling

OFFLINE 6.

Current requirement

Electrical and adapted mechanical¹³ device modelling shall be provided as an open-box.

Justification

This requirement considers the possibility to re-create the electrical and mechanical device model in another simulation tool if needed (refer to the examples given in the Context chapter). To support this possibility, necessary documentation is also important, see OFFLINE 26.

It must be noted that encrypted communication with open-box model is not possible, as it would have to be decrypted by the open-box model and therefore would then be clear.

¹² See [11] for the definition of “subsystem”

¹³ See OFFLINE 10 for more information regarding the need for adapted mechanical model.

OFFLINE 7.

Current requirement

Apart from OFFLINE 6, the wind turbine electrical and mechanical model up to the wind turbine circuit breaker¹⁴ and the valve model can be provided as a tool-independent DLL if this solution:

- is proven by the vendor to be sufficiently equivalent to open-box model that meets all the requirements defined in this document except OFFLINE 6, especially in terms of accuracy. To prove this, it is expected to receive documentation containing a description of the model used as a reference and the result of the studies performed to compare this reference model to the DLL. This documentation is requested for the first delivery and for each update performed on this part of the DLL.
- does not lead to numerical instability issues,
- has adequate modularity considering on-site¹⁵ mechanical and electrical components' refurbishment.

Justification

Vendors raised concern for open-box model due to intellectual property for some specific topics:

- Wind turbine model
- Valve model
- Surge arrester

After a deep analysis:

- For the wind turbine model and the valve model, it has been agreed to offer the black-box DLL possibility, which is the rational for this requirement. Nonetheless, this conclusion only applies in this context of minimum requirement for interaction studies. Outside of this context, system owners may not offer this black box DLL possibility. This should lead to dedicated discussion outside InterOPERA.
- For the surge arrester, open-box model will be provided in InterOPERA, considering that it will be sufficiently accurate. However, in a different context, this open-box model might not be appropriate and vendors might have to provide an improved model that they would like to be black-box. The acceptance of the black-box would have to be discussed in that case.

OFFLINE 8.

Current requirement

The modelling of electrical device shall include an accurate representation of the converter valves¹⁶ (see REAL-TIME HVDC 2), arm inductance, the lines, cables, transformers (including saturation, on load tap

¹⁴ The wind turbine transformer, that is on the collector side of the circuit breaker, is not eligible to the provision of a tool-independent DLL and shall be provided as open-box as per OFFLINE 6.

¹⁵ On-site is used to reference to what would be delivered by a vendor at the customer's site in a real project.

¹⁶ Valve as defined in [4]. It corresponds to one arm, without arm inductance.

changer if applicable), resistors, filter, breaker, AC and DC arrester, or any other electrical equipment having an impact on the studies.

For each electrical device model, one or several models can be provided to better adapt the model to the purpose of the study.

The documents [2] and [3] shall be used as a reference.

Justification

Most likely a single model, that is valid for all investigations, does not exist. It is common practice and agreed state-of-the-art, that each study is conducted using an appropriate model. Therefore, it has been explicitly mentioned that different models could be provided.

It is worth pointing out that documents 2 and 3 are references. However, they are subjected to improvements.

Maturity level

Depending on the lessons learnt during InterOPERA, it will be defined more precisely which studies are needed (see OFFLINE 1 comment) and which models are needed to be able to perform these studies.

OFFLINE 9.

Current requirement

The frequency dependency of electrical devices and transformers shall be taken into account within the range 0.2Hz to 2.5 kHz as defined in OFFLINE 2.

OFFLINE 10.

Mechanical features shall be included in the model if they impact the electrical performance in the frame of interaction studies. The level of modelling shall be adapted to the interaction studies to be performed.

Information

This requirement, initially targeting wind turbine models, is defined as a common requirement to be as generic as possible.

For wind turbine models, aerodynamic and mechanical model is generally embedded with certain approximation/simplifications to limit the complexity of the model while ensuring sufficient accuracy for the studies to be performed, this is why “adapted” adjective is used in this document. It is transparent to the user.

It is mainly expected that the mechanical model ensures a good representation of torsional dynamics, which are of major importance, especially in grid forming mode. Usually, a two-mass model is used.

OFFLINE 11.

Current requirement

Electrical devices which do not impact the studies to be performed shall not be part of the model.

Example

Earthing/grounding switches only used for earth state shall not be included; but grounding system influencing the behavior of the system in operation shall be included.

Justification

This is to optimize the model to its use, with lower computing time and lower risks of mistake.

1.1.2.2 Requirements on control and protection modelling

OFFLINE 12.

Current requirement

Control and protection code shall:

- (1) Not be dependent on a specific tool, solver, compiler or linker version, except for few compiler options which shall be defined (non-exhaustive list):
 - Calling convention: `__cdecl (/Gd)`
 - Runtime Library: multithreaded DLL (`/MD`)
- (2) If black-boxed, be in a pre-compiled and built DLL format, in 32 and in 64 bit-word, in line with the above-mentioned compiler options, and compatible with the snapshot functionality of EMT simulation tools.
- (3) Be based on the real control and protection code, and with adequate accuracy to perform the interaction studies. All control and protection functions shall be included, except if not relevant for the interaction studies.¹⁷
- (4) Respect at least the model structure, the signal interface list and accessibility requirements defined in this document.
- (5) Have only instantaneous input/output signals. For example, if RMS signals are requested by the control and protection system, then the appropriate algorithm shall be included inside the control and protection model.

Optionally, the guideline [8] can be used as a reference for the use of real code in EMT models.

¹⁷ The on-load tap changer has usually a low-speed operating logic, so that its effects are not visible during short duration interaction studies. However, it shall be possible to start the studies with the right tap changer position. Consequently, a control logic shall be provided to be in the right default position for a given voltage. Additionally, a manual mode shall be provided to be able to change the default position to another one (for example, to consider the hysteresis).

Justification

Points 1 and 2: this is requested because different simulation tools might have to be used for the studies (refer to the Context chapter). But currently, without these requirements, it is observed that it is often difficult to use a DLL provided for one version of one tool and one compiler version, with another tool, another compiler. A lot of efforts and back and forth with vendors are currently necessary for DLLs that are not tool and compiler independent.

If it is expected to use the model with 32-bit word and 64-bit word tools, then two DLLs shall be provided, one in 32-bit word and one in 64-bit word, because the bit-word size is compiler dependent.

Point 3: this is for an appropriate reliability of the results. Measurement signal processing, such as filters, is considered included in this requirement and shall be represented with adequate accuracy.

Point 4: this is for the usability of the models by the recipients. The term "At least" is mentioned here because this document is focused on the minimum requirements for models to be used for interaction studies with strong vendors' support. Consequently, on top of these minimum requirements, for their specific needs, system owners can ask for additional requirements, for example based on [6] where more signals, with a specific order of inputs and outputs, and more modularity are proposed. This is proposed by [1], where it is written that "the model structure and signal interface should be based on public documents or standards if available". Discussion for those additional requirements should take place outside of InterOPERA.

Point 3 and 5: to achieve point 5, the real code of measurement signal processing – with an accuracy limited to the interaction studies need - is expected, as per point 3. If this real code is not at the hand of the vendor (use of third-party equipment), the vendor can propose a deviation to the requirement, and provide instead a model reflecting the signal processing to its best knowledge. In such a case, this deviation shall be duly documented.

Maturity level

Point 4: During InterOPERA, with the lessons learnt, it will be assessed if the minimum proposed in this document is sufficient or if it should be reinforced.

OFFLINE 13.

Current requirement

Adequate modularity shall be forecasted for the DLL for easier testing and debugging:

- Each station shall be interfaced with the simulation tool through its own interfaces and its own DLL(s) call(s). Thus, different stations should have different DLLs or different instances of the same DLL (for example: two converter stations provided by the same vendor shall have two different interfaces in the simulation tool)
- Within one station (e.g. one converter station), specific requirements are given in OFFLINE HVDC 3, OFFLINE DCSS 3 and OFFLINE DCSS 5.

Information

WP2, D2.1 definition of “station” functional level is to be used to correctly understand this requirement. A station can be PPM, AC switching station, AC/DC converter station, DC/DC converter station, Energy storage system, Current flow controller, Energy absorber, DC switching station. To simplify the way the requirement is written, the DC Grid controller shall also be considered as one “station” in this context.

Maturity level

Proposal for the “adequate” modularity is done on a case-by-case basis in this document. This can evolve based on the lessons learnt during InterOPERA.

OFFLINE 14.

Current requirement

The limit of the scope of the supply is defined in *Figure 2*:

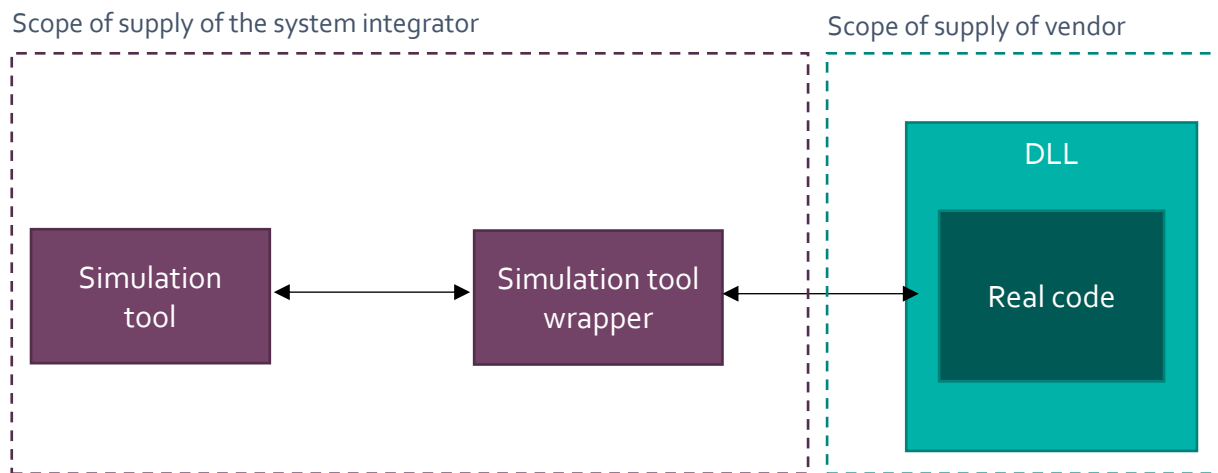

Figure 2 – Limit of the scope of the supply.

The simulation tool wrapper – intermediate code facilitating communication between the tool and the DLL during the simulation – is not part of the scope of supply of the vendor but the code-wrapper to put the real-code into the DLL format is in the scope of supply of the vendor.

Justification

This is to clarify the limit of the scope of supply.

OFFLINE 15.

Current requirement

It shall be possible to change all the parameters and settings needed for performing the studies.

Additional future requirement

By default, for commercial projects, the parameters and settings shall match the site-specific parameters and settings.

OFFLINE 16.

Current requirement

Input/output signals with third-party systems shall be included in the model.

The communication delay for these signals shall be settable.

Justification

Point 1: This is obvious.

Point 2: This is requested because communication delay can impact the results.

OFFLINE 17.

Current requirement

Delays due to internal communication (for example: between measurement and control, between controllers, etc.) shall be included in the model.

Justification

This is requested because these delays can impact the results.

OFFLINE 18.

Current requirement

For subsystems with a start-up sequence on site, the start-up sequence shall be modelled as an accelerated sequence, focusing on the phenomena linked to the energization of the components and useful to study the impact of the energization of the subsystem on the rest of the system already in operation.

OFFLINE 19.

Current requirement

Outside the context of energization studies, for its initialization, the model shall include a flat-start functionality, using initialization references as inputs. As long as the flat-start mode is active, the model shall not be disturbed by the initialization of other models connected to the same circuit.

It shall smoothly switch from flat-start mode to regular mode after receiving a dedicated signal. During 5 extra seconds, for the rest of the system to reach steady-state, it shall neither trip nor send misleading information to other subsystems.

The flat-start mode does not exclude using the accelerated energization sequence from the initialization of the model, but offers the opportunity not to include it, in order to speed up the initialization of the model and to fit with the maximum allocated time defined for the initialization in stand-alone.

If the flat-start mode does not include the accelerated energization sequence, then, it shall be possible to select which option is to be used when initializing the model, to fulfill both OFFLINE 18 for energization studies and this requirement for other interaction studies.

Information

The initialization of the model is distinguished from the energization of the model. Indeed, the energization of a subsystem is only of interest to analyze its impact on a system already in operation; whereas the initialization of the model is necessary to prepare the system, in order to perform the interaction studies.

1.1.2.3 Requirements on simulation step range

OFFLINE 20.

Current requirement

The model shall be compatible for a simulation step equal to 10 μ s and 20 μ s.

If necessary, different models can be delivered to adapt to the time steps.

Information

The time steps defined here are the time step of the offline simulation tool. This is not necessary the time step of the control blocks. See next requirement for that.

It is acceptable not to have the exact same results for all the time steps as long as the accuracy remains sufficient for the studies to be performed.

Justification

- It is proposed to go up to 20 μ s, as for certain studies this can be a good compromise between calculation time and need for quality. For example, 20 μ s is adapted for interaction up to 2.5 kHz and is in line with [9]. For higher frequency interactions studies, 20 μ s might not be appropriate.
- The minimum has been fixed to 10 μ s, in line with [9].
- By comparison with [9], only pre-determined time steps have been defined, instead of a continuous range, for a better testability of the requirement.
- Besides, it is proposed to have several time steps, to increase the chances of finding time steps that are suitable for all the models.

It is proposed to provide different models if necessary, because based on current situation, some models are specifically developed for lower time steps, and don't fit for higher time steps. In that case, for higher time steps, a different model, less detailed but still fitting for the interaction studies up to 2.5 kHz, is provided.

Maturity level

There are currently some limitations on the way the sampling time is managed by the DLL: it is fixed and not variable. Proposals for improvement are made in the DLL documentation. The impacts shall be assessed.

OFFLINE 21.

Current requirement

Within the DLL, the control system shall use the sampling time of the real control system, knowing that the call of the DLL is managed by the simulation tool, based on the sampling time parameter indicated in the DLL. If multiple sampling times are necessary within one DLL, this shall be handled by the DLL owner.

Information

More information on the way the coordination is done between the simulation tool and the DLL is given in the DLL documentation.

Justification

This is already current practice and the vendors already have solutions for DLL to manage this requirement, even for frequency dependent sampling times.

Maturity level

This is the estimated minimum requirement for interaction studies.

For their specific needs, system owners can request to have the interpolation outside of the DLLs. In such case, discussion for this additional requirement shall happen outside of InterOPERA.

But in case of troubles during InterOPERA, this additional requirement related to the interpolation will be discussed in InterOPERA.

1.1.2.4 Parallelization and multiple instantiation

OFFLINE 22.

Current requirement

It shall be possible to run simulation:

- with multiple instances of the same model in the same simulation:
 - running on one process
 - running on multiple processes¹⁸
- with multiple instances of the same model on different simulations, running on multiple processes¹⁹ in parallel.

Justification

Point 1: this can be the case when a vendor provides multiple stations, based on duplicated model, connected to the same grid, and therefore part of the same simulation. It can run on multiple processes when parallel computing is used.

1.1.2.5 Modular design for integration in multi-vendor model scheme

OFFLINE 23.

Current requirement

It shall be possible to integrate the provided model in simulations using models from other vendors.

OFFLINE 24.

Current requirement

It shall be possible to integrate the model in any electrical circuit, corresponding to the topology or topologies for which the model has been designed (i.e. same voltage level, same power) and aiming at performing the studies defined in OFFLINE 1, this circuit not being provided with the initial model.

The use of layers²⁰ is not permitted.

Justification

The reason for this requirement is that sometimes, vendors develop the model with a certain circuit and there might be invisible adhesion between the model and the circuit, which becomes visible once the model is used in another circuit.

Information

This requirement has been deeply discussed to avoid misunderstanding on the meaning of “any” circuit. Every model has a limited validity area, the purpose is not to use the model out of this validity area.

OFFLINE 25.

¹⁸ These processes can be on the same or on different cores.

¹⁹ Same remark.

²⁰ Layers are a feature proposed by PSCAD.

Current requirement

Considering OFFLINE 22, OFFLINE 23 and OFFLINE 24, it must not conflict from a numerical point of view. For example, no global variables shall be used. It must not rely on shared memory addresses that could be accessed or used by other DLLs (provided by the same vendor or by another one).

Justification

This comes from the lessons learnt during previous studies where models from different vendors had to be used in the same simulation.

Maturity level

The list of examples could be extended based on the tests to be performed in InterOPERA.

1.1.3 Documentation

OFFLINE 26.

Current requirement

The provided models shall be well documented:

- OFFLINE 7, OFFLINE 28, OFFLINE 29 and OFFLINE 31 shall be considered
- For electrical equipment: single line diagram (with earthing switch included) and parameters shall be provided. The level of description shall be such that it is possible to create an EMT model from it²¹, without considering cable aggregation.²²
- Fundamental simplification (such as conservative measures taken for margin, leading to poorer performance compared to what would be observed at site) shall be mentioned (*)
- Name and version of the simulation software used, and compiler version shall be given
- A short high-level description of all the files shall be provided, with the main purpose of each file and how the files interact with each other (ex: if a file is called by another file)
- Description of the content of the DLL shall be provided:
 - Explanation of the usage rules: conditions under which the model can be used, its limitations or restrictions
 - Explanation of the input and outputs signals, including data type, unit of measurement, range, purpose, function, signal processing and sampling time if different from the simulation time step. The level of description shall allow to connect the signals and interpret them correctly. (**)
 - Explanation of all the accessible parameters and settings: ranges, default value and purpose.
 - The list of all the protections shall be provided, with an explanation of which protections are selected and included in the model. *In InterOPERA specific context, it is proposed to list at least one protection that is not included to check that the requirements OFFLINE HVDC 4, OFFLINE PPM 6 are correctly understood. (***)*
 - Clear instructions shall be given for signal accessibility management: if needed, which signals can be shared with a third-party?

²¹ This is in case the open-box model cannot be open with the EMT tool of the recipient.

²² This is the minimum. Aggregated data can be requested on top.

The terminology used shall be aligned with the one specified in the functional requirements and in the vendor’s control specification to avoid misinterpretation.

Additionally to the model documentation, the vendor shall provide its control specification which describes how the functional requirements are implemented (*in InterOPERA, the function requirements and control specification are prepared respectively in tasks T3.2 and T3.3*). Indeed, this control specification is useful to describe which functions are implemented.

Justification

(*): “Fundamental” simplification is a subjective definition and will certainly need to be refined based on the lessons learnt.

Conservative measures have been discussed in InterOPERA. As current practice, vendors can voluntarily degrade the performance of the models compared to real behavior, for example by not considering some damping effects of the transformer, to validate the system with the most constraining case and to benefit from some margin. In the current version of the document, it is simply required to document this approach. In future versions, based on discussion to be held on D1.3 and based on the lessons learnt, this requirement might evolve. For example, one can imagine that a specific requirement for a model without conservative margin could be created (to be used if the tests fail with the conservative margin), and that a second optional model with conservative margin could be proposed.

(**) The documentation is strongly linked to the way the DLL is provided for control and protection, i.e. in how many blocks it is split. Here, the assumption is that it is limited to few “big” blocks, with limited signals. Therefore, it is more acceptable for the vendor to provide full description of these signals.

(***) When choosing protection measures, it is important to refer to the fault location diagram for guidance and clarification (ex: [Figure 5: Example of fault location in a converter station](#)); this diagram being specifically forecasted for interaction studies and not for any study.

To limit the extra-work in InterOPERA for the vendors, it is proposed to limit to one protection that is not included in the model, such as the transformer differential protection.

1.1.4 Maintainability and updates

Maturity level / how to use these requirements for real projects

This set of requirements for maintainability and updates focus here on InterOPERA context. For real projects, additional requirements might be needed and will be discussed in the next version.

OFFLINE 27.

Current requirement

A new model, fulfilling the same requirements as the previous one, shall be provided every time a correction/update is deemed necessary for performing the studies.

OFFLINE 28.

Current requirement

A document shall be delivered to explain the differences between the previous model and new model and to list the non-regression tests²³ to be performed to the vendor's best knowledge to check this new model.

Justification

This is for the recipient to know what to update in his existing simulation, and what to test to check that everything is still working fine with the new model.

OFFLINE 29.

Current requirement

A version tracking document shall list all the updates and shall mention the associated identification number.

Justification

This is for quality management and traceability. Reference to this version tracking document will be made to explain which result has been provided with which model.

OFFLINE 30.

Current requirement

The delivery of a new model shall be self-supporting and shall include all files (documentation, electrical model representation, DLL, version tracking document, etc.)

Justification

This is based on previous lessons learnt, where only some parts were delivered and people could get lost to have the full picture and make sure that they had all the parts up to date.

OFFLINE 31.

Current requirement

All models, documents shall have a unique identification name based on the updates' number (ex: vx.y, x for major updates and y for minor updates).

Justification

This is based on previous lessons learnt where people could get lost without this requirement.

²³ Non-regression tests aim at checking that no issues have been introduced involuntarily in the system due to the changes. The tests that were previously successful shall remain successful. In other words, it demonstrates that there is no regression.

1.2 Requirements for offline models – specific to DC grid controller

OFFLINE DCGC 1.

It shall be possible:

- to use the DC Grid Controller to control the subsystems' energization,
- to start the DC Grid Controller with the grid in operation, and to make it active in less than 3 s.

Information

The first point reflects the possibility to send commands to start each subsystem with the accelerated sequences, for energization studies.

The second point is to be used in association with the flat-start functionality.

OFFLINE DCGC 2.

It shall be possible to adapt the sequential control of the DC Grid controller model to the context of offline studies.

Explanation

If the DC Grid Controller relies on fix time delays for the sequences or between sequences, based on the real subsystem sequences, then it shall be possible to change the time delays for the sequences or between sequences, knowing that in offline, the purpose of the energization studies is to focus on the electro-magnetic phenomena, and that consequently, accelerated sequences are expected, as per OFFLINE 18.

Another option is that the DC Grid Controller relies only on signals. In such a case, nothing specific is expected through this requirement.

1.3 Requirements for offline models – specific to HVDC converter station

1.3.1 Structure and content of models

OFFLINE HVDC 1.

Current requirement

One model for HVDC Converter station is defined as the block containing the following items:

- Electrical interfaces with the grid, AC and DC side
- Inputs/outputs with third-party system. *(In InterOPERA, third-party system means DC Grid Controller, DC switching station as it will be defined in WP2 and WP3)*
- power model for the HVDC Converter station (2 converter units for one bipolar converter station)
- control system for the HVDC Converter station
- protection system for the HVDC Converter station

OFFLINE HVDC 2.

Current requirement

At the first level of access, the model shall be represented as one block:

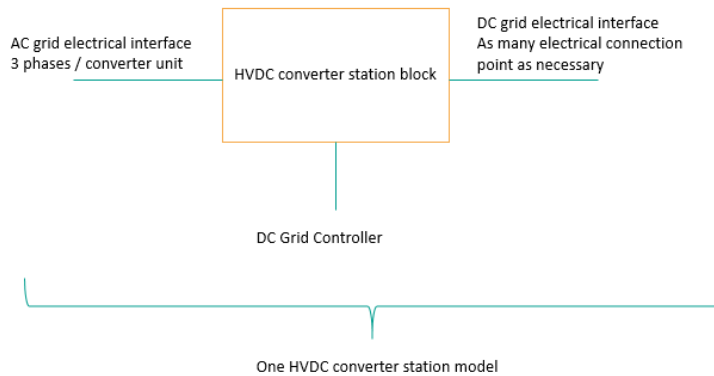

Figure 3: Example of HVDC converter station model structure at the first level of access

Information

In the example, only the DC Grid Controller is listed as the third-party system. But depending on the results of other WPs in InterOPERA, it might happen that input/output with other systems are necessary.

OFFLINE HVDC 3.

Current requirement

At the second level of access, at least two blocks shall be visible, to distinguish the power model from the control and protection system. It is the freedom of the vendor providing C&P DLLs to provide control and protection in two separate DLLs (and thus being visible as two blocks) or in a single DLL.

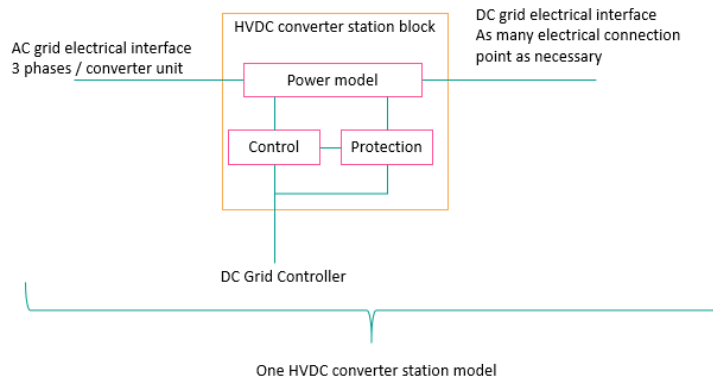

Figure 4: Example of HVDC Converter station model structure at the second level of access, considering the case where the vendor chooses to provide control and protection in two separate DLLs.

Maturity level

TSOs prefer to split between control and protection for higher modularity. However, as it can lead to extensive work on the vendor side, it is expected by the vendors that the need is better justified before making this preference a strong requirement. Therefore, this requirement could evolve in the future.

Besides, control is not split here in multiple layers as per [6] ([ENTSO-E Standardized control interface update 2020 07 15 .pdf](#)), for the reasons explained in the T&D Europe paper ([TD Europe proposal HVDC deployment 15 Jan 2020.pdf](#)). In InterOPERA, it will be observed if not having the control split in different DLL is blocking the resolution process in case of interactions, or if this risk is covered by defining the relevant signal list. In case the resolution process is blocked during InterOPERA, a decision-making file will be prepared as per the decision-making process. The request to split in different DLL will be studied as one of the options in this decision-making file. D1.1 would then be updated depending on the conclusion of this process.

D1.1 being the minimum requirements, system owners can request as an additional requirement to split between control and protection and/or to split the control in multiple layers depending on the real control system architecture, for example with one DLL per processor. In such case, discussion shall happen outside InterOPERA.

OFFLINE HVDC 4.

Current requirement

To evaluate which protections²⁴ shall be included in the model or is not necessary, it is specified that it shall be possible to detect faults located on bus between components but not within the components themselves. For example, there can be a fault triggered at the primary side of the transformer, at the secondary side of the transformer, or on the DC bus before the DC disconnect. But faults will not be triggered on the transformer itself, between or on valve sub-modules. The diagram below illustrates this principle but does not presume of the design of the converter station (ex: optional DC chopper is not represented):

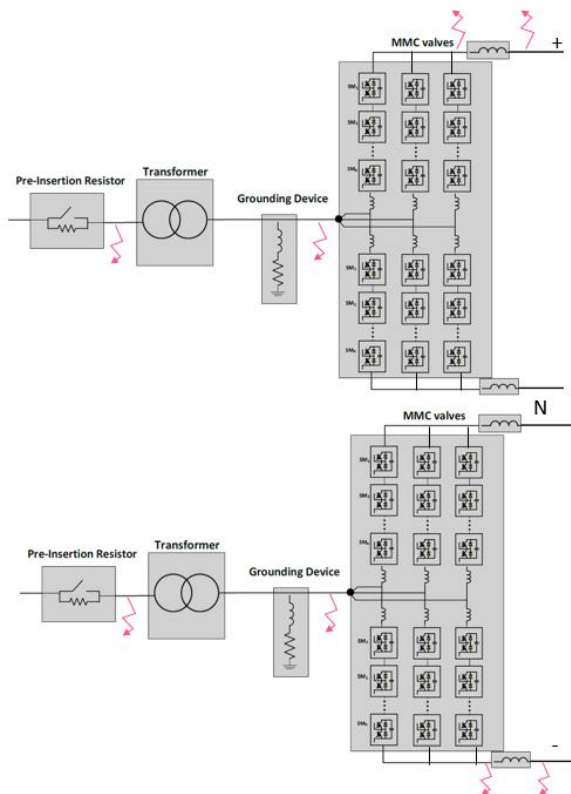

Figure 5: Example of fault location in a converter station

In addition, depending on the functional requirements – or on WP3 scope of supply within InterOPERA –, protection of components outside the converter station itself (ex: DC cables) shall be considered.

1.3.2 Model performance

²⁴ The classic list of protection is : Transformer Differential Protection, Transformer Restricted Earth Fault Protection, AC Filter Bus Protections, AC Filter Bus Differential Protection, AC Filter Bus Abnormal Voltage Protection, AC Filter Bus Neutral Voltage Protection, Abnormal Frequency Protection, Low Modulation Index Protection, Harmonic Distortion Protection, AC Filter Protections, AC Filter Capacitor Unbalance Protection, AC Filter Resistor/Reactor Overload Protection, AC Filter Capacitor Overload Protection, Converter Valve Protections, Converter Overcurrent Protection, Converter Thermal Overload Protection, AC Terminal Short-circuit Protection, DC Chopper Protections, Chopper Resistor Short-circuit Protection, Chopper Resistor Impedance Protection, Chopper Resistor Protection, Converter DC Protections, DC Abnormal Voltage Protection, DC Cable Fault Indicator, SSTI Protection

OFFLINE HVDC 5.

Current requirement

The maximum initializing time shall be 5 s, in single-vendor operation, considering OFFLINE 19. This means that steady-state values (e.g.: active and reactive power, voltage, frequency, tap changer position, etc.), in a band of +/- 5%, shall be reached before 5 seconds of simulation, making it possible to perform events (e.g.: AC/DC faults) at 5.1 seconds.

Information

The 5 s maximum initializing time is evaluated during single-vendor tests.

OFFLINE HVDC 6.

Current requirement

Considering OFFLINE 18, the accelerated start-up sequence shall take less than 5 s.

1.3.3 Parameter and data accessibility for control

OFFLINE HVDC 7.

Current requirement

Access shall be provided to:

- The relevant parameters and set points of the control functions, as defined in the functional requirements (*)
- The activation/deactivation of control functions (ex: active damping function), as defined in the functional requirements (*)
- The “enabled/disabled” option of a protection (**)
- The parameters of the DBS (if any)

Justification

This requirement gives some details, of what can be expected with OFFLINE 15

(*): reference is made to the functional requirements to limit to the control functions that are generally at the hand of networks planning and operator. In InterOPERA phase 2, the functional requirements correspond to task 3.3 deliverable.

(**): normally, the models are adapted to the studies that are performed at the different stages of the projects, so that the content of the protections is handled by the vendor. But there is some concern about the need to disable the protections during energization.

Maturity level

Access to the protection’s settings is not written for now, because during InterOPERA, there will always be the vendor’s support. Vendors will update the settings if needed, this is their responsibility.

But for commercial projects, it seems necessary for the system owners to have access to these settings.

1.3.4 Signals

OFFLINE HVDC 8.

Current requirement

The following signals shall be accessed:

- Desired mode of operation (Statcom...), as defined by the operator (if applicable)²⁵
- Actual mode of operation
- AC-side active-power reference values, positive and negative sequence (if applicable)²⁶
- Active power order and ramp, as defined by the operator
- AC-side active-power measured values at the PCC-AC and at the transformer line side winding, positive and negative sequence (if applicable)²⁷
- Status of the main control functions (enabled/disabled/activated/released)
- Max/Min active power capacity limit (steady state value)
- AC-side reactive-power reference values, positive and negative sequence (if applicable)²⁸
- Reactive power order or Vac (AC Voltage at PCC-AC) order and slope, as defined by the operator
- AC-side reactive-power actual values at the PCC-AC and at the transformer line side winding, positive and negative sequence (if applicable)²⁹
- AC-side voltage-magnitude reference values, positive and negative sequence (if applicable)
- AC-side voltage-magnitude actual values: positive, negative and zero sequence voltage calculated by control system at PCC-AC, converter transformer primary and secondary sides
- Actual AC-grid and converter transformer secondary side voltage measurement values (phase-to-ground instantaneous voltages)
- Max/Min reactive power capacity limit (steady state value)
- AC-side grid-frequency reference value
- AC-side grid-frequency actual value at the PCC-AC
- Actual AC-grid and converter transformer secondary side current measurement
- Positive, negative and zero sequence currents calculated by control system at PCC-AC, transformer primary side (if applicable)
- DC current in converter transformer converter side (3 phases)
- Tap position (if any)
- Current in high impedance grounding system (if applicable)
- Aggregated blocking command

²⁵ It can be defined locally by the operator, on the HMI, or remotely, from the dispatch center, from the DC grid controller, etc. It is worth pointing out that this is limited by the availability of the mode of operation in the system. An operator may for example not be able to request a specific control mode when the system is not energized.

²⁶ The mathematical definition of the positive and negative sequences for active power is given in IEC Standard 61400-21-1:2019, "Wind energy generation systems - Part 21-1: Measurement and assessment of electrical characteristics - Wind turbines"

²⁷ As defined in IEC Standard 61400-21-1:2019, "Wind energy generation systems - Part 21-1: Measurement and assessment of electrical characteristics - Wind turbines"

²⁸ As defined in IEC Standard 61400-21-1:2019, "Wind energy generation systems - Part 21-1: Measurement and assessment of electrical characteristics - Wind turbines"

²⁹ As defined in IEC Standard 61400-21-1:2019, "Wind energy generation systems - Part 21-1: Measurement and assessment of electrical characteristics - Wind turbines"

- Aggregated actual blocking state
- Main converter station protection signals and tripping instant, with the possibility to identify the protection which tripped, except for inner converter protections
- Actual values for arm voltage (for 6 arms)
- Actual arm current-measurement values – 6 arms
- DC-side voltage-magnitude reference value for positive/negative side
- Actual DC-grid (positive/negative and neutral side) voltage measurement values, before and after eventual DC electromagnetic circuit
- DC voltage, before and after eventual DC electromagnetic circuit, as calculated by the control system
- Actual DC-grid (positive/negative and neutral side) current measurement before and after eventual DC electromagnetic circuit (if applicable)
- DC side setpoint, as defined by the operator
- DC side reference value, used by the control system
- Binaries indicating if the converter is in a special mode of operation, limited to the special modes of operation defined in the functional requirements, *in WP2 and in WP3 in InterOPERA*.³⁰
- Activation/Deactivation of the DBS (if any)
- Chopper state (available or not) (if applicable)

Justification

This initial list is based on signals already commonly shared by the vendors for the TSOs to perform interaction studies, mainly with the AC grid. In addition, some signals have been added to consider the new functional requirements defined in [11].

Only the strict minimum signals are included in this list for better IP protection.

Maturity level

If this is duly justified, based on the interactions that will be observed during InterOPERA interaction studies, this list can evolve and request for more signal access.

³⁰ These special modes of operation are the ones defined by the system owners in the functional requirements. They are different from the special modes of operation which are internally developed by the vendor for better performances, and which are protected by IP.

1.4 Requirements for offline models – specific to PPM

1.4.1 Structure and content of models

Information

In InterOPERA definition (see [11]), PPM is one subsystem. However, for more flexibility, and to reflect the possibility of having different suppliers for the WTs and the PPC, in the context of this document related to the delivery of models, the WT model and the PPC model are considered as two separate models.

OFFLINE PPM 1.

Current requirement

The vendor shall provide a wind turbine model consisting of:

- The adapted aerodynamic and mechanical model
- The electrical power model
- The control of the wind turbine
- The protection³¹ of the wind turbine
- 3 phases electrical interface with the grid collector
- Interface with the power plant controller
- Interface for the mechanical available power, that can be extracted from the wind.

Justification

As the detailed aerodynamic part is not requested for interaction studies, instead of the wind speed, there is a preference to use directly the resulting available power as an input.

OFFLINE PPM 2.

Current requirement

The vendor shall provide a power plant controller model consisting of:

- The control of the power plant
- Interface with the grid (for example for measurement)
- Interface with the wind turbines control and protection system
- Interface with a third-party system, such as the DC grid controller.

OFFLINE PPM 3.

Optional future requirement

Optionally, it can be requested to provide the model of the grid collector. It includes the electrical model as well as the control and protection model³², between the PoC of the wind power plant and the PoC of

³¹ The protections to be considered are the protections operating the circuit breaker.

³² This can be for example the protection which can trip the main CB.

the wind turbines. In such a case, a semi-aggregated model shall be provided, with each string modelled as an equivalent string with all the wind turbines belonging to the same string aggregated. In addition, a fully aggregated model can also be requested, with all the strings aggregated.

For both the semi-aggregated and the fully aggregated models, the requirements related to the documentation fully applies (the detailed data of each string, without considering any aggregation at all, shall be provided). In addition, a report shall be provided to explain the aggregation methodology used, and test results shall be included in this report to justify the relevance of the methodology and the validity of the semi and fully aggregated models.

Information

In InterOPERA, the grid modelling and protection between the PoC of the wind power plant and the PoC of each individual wind turbine, is in the scope of supply of the system integrator. Thus, only the wind turbine model and power plant controller model are expected to be provided by the wind turbine vendors.

For real projects, there are other options and requirements related to the grid collector model can be added.

If the control and protection is provided by a third-party, the vendor can ask for a deviation to the requirements, to provide a model based on its best knowledge (that is not the real control and protection code), while ensuring that it is still sufficiently accurate for the studies to be performed.

OFFLINE PPM 4.

Current requirement

It shall be possible to connect several units of these wind turbine models to one power plant controller model. The number of wind turbines to be connected shall be selectable.

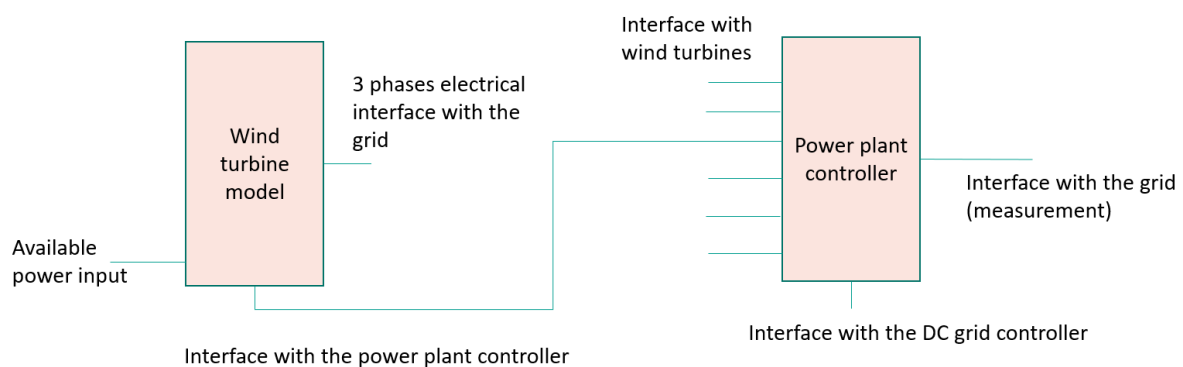

Figure 6: An illustration of the expected structure for the models

OFFLINE PPM 5.

Current requirement

It shall be possible to use parallel computing with several units of these wind turbine models connected to the same power plant controller model.

Justification

To optimize the calculation time, one could imagine using parallel computing for the wind turbines.

OFFLINE PPM 6.

Current requirement

To evaluate which protections shall be included in the model or is not necessary, it is specified that it shall be possible to detect faults located on bus between components but not within the components themselves and not between wind turbines connected to the same inter array cable. For example, there can be a fault triggered at the primary side of the grid main transformer or at the secondary side of the grid main transformer. But faults will not be triggered on the transformer itself, and not on wind turbines.

The diagram below illustrates this principle:

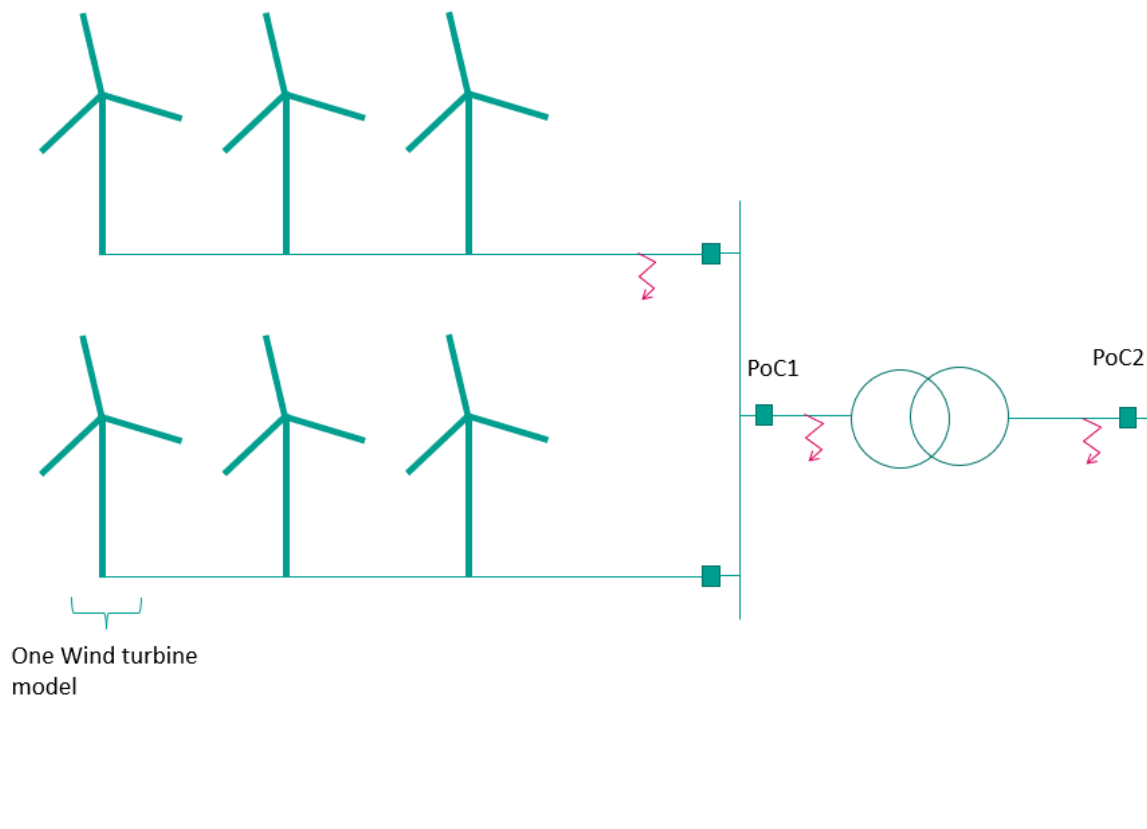

Figure 7: Possible fault location for PPM

Information

The diagram is a fictive example, aiming only at showing that there will be no faults between wind turbines, on wind turbine, and on the transformer. It does not presume of the layout.

The transformer represented on the diagram could be the main wind power plant transformer (in which case the point of coupling is PoC2), or one could imagine different topologies, with direct connection to the AC grid (without a wind power plant transformer), in which case the transformer represented here would be the converter station transformer, and the point of coupling would be PoC1.

Besides, the main assumption made here is that, for interaction studies as the Point of Connection, it is neither necessary to perform faults between the WT's nor to perform internal faults in the WT's. This comes from the lessons learned with the WT's in grid following mode. However, in the future, grid forming by the WT's is expected. Consequently, detailed studies will have to be carried out by the vendors to confirm that this assumption is still valid. If the validity is not proven, then faults between the WT and in the WT will have to be considered.

1.4.2 Model performance

OFFLINE PPM 7.

Current requirement

The maximum initialization time shall be less than 4 s. In that amount of time, the system has reached steady-state and is operating at any active/reactive power within the PQ diagram.

Justification

This is based on current practice.

OFFLINE PPM 8.

Current requirement

It shall be possible to energize the wind turbine after the start of the simulation, through a dedicated signal.

Justification

For more flexibility, a dedicated signal is proposed here for the start of the wind turbines, instead of an automatic start.

1.4.3 Signals

OFFLINE PPM 9.

Current requirement

At least, the following signals for each wind turbine, coming from the control and protection system itself, shall be accessible:

- Signals used as control references (ex: AC voltage reference, frequency or power reference, setpoint...)
- All voltages and currents measured by the C&P system, including DC side
- Calculated power (mechanical and electrical) (if available)
- Blade's and Generator's speed (if available)

- Pitch angle (if available³³)
- Transformer tap changer position (if any)
- Status of the converters (grid side, generator side) : blocked, deblocked (if applicable)
- Trip indication, one signal per main protection zone. It shall be possible to identify the protection which tripped.

Maturity level

This is a first proposal. It will be assessed during InterOPERA if more signals are needed.

Mechanical power and generator speed shall be further discussed. From a result-oriented perspective, the added value is limited (no losses apart from dissipation, no storage considered), so it is maybe equivalent to look at the electrical part. But from analysis perspective, it might be useful to see the benefit of the inertia of the turbine.

OFFLINE PPM 10.

Current requirement

At least, the following signals for each power plant controller, coming from the control itself, shall be accessible:

- Signals used as control reference
- Targets sent to the wind turbine.

Maturity level

This is a first proposal. It will be assessed during InterOPERA if more signals are needed.

³³ The availability of this signal depends on the functions that are included in the model, based on the functional requirements.

1.5 Requirements for offline models – specific to DC switching station

1.5.1 Structure and content of models

OFFLINE DCSS 1.

Current requirement

A DC Switching station model consists of:

- The power model representing all the necessary high voltage components
- The control
- The protection (if any)
- Interfaces:
 - As many electrical interfaces with the DC sides as per topology
 - Inputs/outputs with third-party systems as per functional requirements (DC Grid controller, HVDC converter station,...)

OFFLINE DCSS 2.

Current requirement

At the first level of access, the model shall be visible as one block:

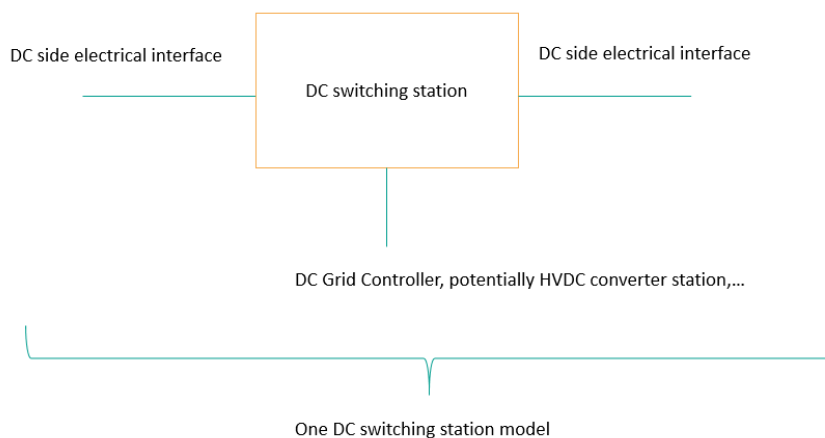

Figure 8: Example of DC switching station model structure at the first level of access

OFFLINE DCSS 3.

Current requirement

At the second level of access, at least two blocks shall be visible, to distinguish the power model from the control and protection system. It is the freedom of the vendor providing C&P DLLs to provide control and protection in two separate DLLs (and thus being visible as two blocks) or in a single DLL.

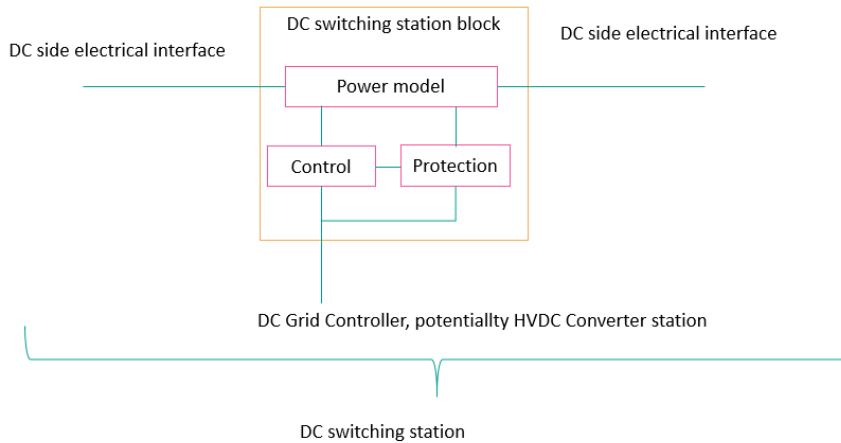

Figure 9: Example of DC switching station model structure at the second level of access, considering the case where the vendor chooses to provide control and protection in two separate DLLs.

OFFLINE DCSS 4.

Current requirement

To evaluate the need for protection during the tests, it is anticipated that electrical faults can be located on the DC bus between components but not within the components themselves. For example, there can be a fault triggered on the DC bus but not on the DC Circuit breaker.

In addition, depending on the functional requirements – *or on WP3 scope of supply within InterOPERA -*, protection of components outside the DC switching station itself (ex : DC cables) shall be considered, if the provision of the protection is included in the scope of supply of the DC switching station.

Information (limited to InterOPERA)

In InterOPERA, the need for protection shall also consider the demonstrator specific framework.

OFFLINE DCSS 5.

Current requirement

If a DC Switching station is made of electrical devices, control and protection provided by different vendors, it is expected to have the associated power model, control and protection provided in separate blocks, with at least one block per vendor.

Justification

This is to consider the case where the DC Circuit breaker of one DC switching unit is provided by another vendor. The purpose is to have the modularity of the models aligned with the real modularity.

1.5.2 Model performance

OFFLINE DCSS 6.



Current requirement

The maximum initialization time shall be less than 3 s.

Maturity level

This is a first guess and can be adapted based on lessons learnt during InterOPERA.

1.5.3 Signals

OFFLINE DCSS 7.

Current requirement

The following signals shall be accessible, if applicable:

- protection signals and tripping instant, with the possibility to identify the protection which tripped.
- Communication signals between DC circuit breakers (if applicable).

Justification

Most of the signals will already be accessible:

- through the separation between the power part and the control and protection part
- through other inputs/outputs of the control and protection with third party subsystem.

This is the reason why the list is quite short.

The tripping instant is defined as the rising edge of the binary signal emitted from the protection requesting the trip.

2 Requirements for hardware and software in the loop

2.1 Requirements applicable to all vendors

2.1.1 Typical layout for the real-time simulation platform

Information

The real-time simulation test setup consists of:

- A real-time simulator (RTS) provided by the system integrator. On this simulator, the electrical behavior of the grid is simulated in real-time.
- Control, protection and telecommunication systems provided by the vendors. It can be the control, protection and telecommunication system of:
 - a converter station
 - a power plant module
 - a DC grid controller
 - a DC switching station,
 - etc.
- Models of electrical and mechanical components to be provided by the vendors, if they are part of the station to be delivered, or by the system integrator otherwise.

Each C&P system, except the DC Grid Controller³⁴, is interfaced to the RTS to provide the required signal exchange between the simulation and the original C&P systems components.

Each C&P system is also interfaced to the telecommunication network for the communication for grid coordination *as defined in WP2*. For a given system, to refer to the other systems which are communicating with that given system, the term “third-party” is used. For example, the DC grid controller is considered as a third-party system by all the converter stations, DC switching stations, PPMs. Reversely, all the converter stations, DC switching stations, PPMs are considered as third-party systems by the DC grid controller.

Communication between each system and the dispatch center is not part of the interaction studies for InterOPERA. The added value of considering communication with the dispatch center for interaction studies for real project shall be assessed. If necessary, additional requirements shall be written.

³⁴ This is the baseline considering that there is only Hardware-in-the-Loop (HIL). However, as per REAL-TIME 1, Software-in-the-Loop can be proposed by a vendor. In such a case, if a C&P system is provided as Software-in-the-Loop (a PPM, a DC switching station, etc. or maybe the DC Grid Controller itself), the DC Grid Controller will be also interfaced to the RTS.

This principle is illustrated in Figure 10.

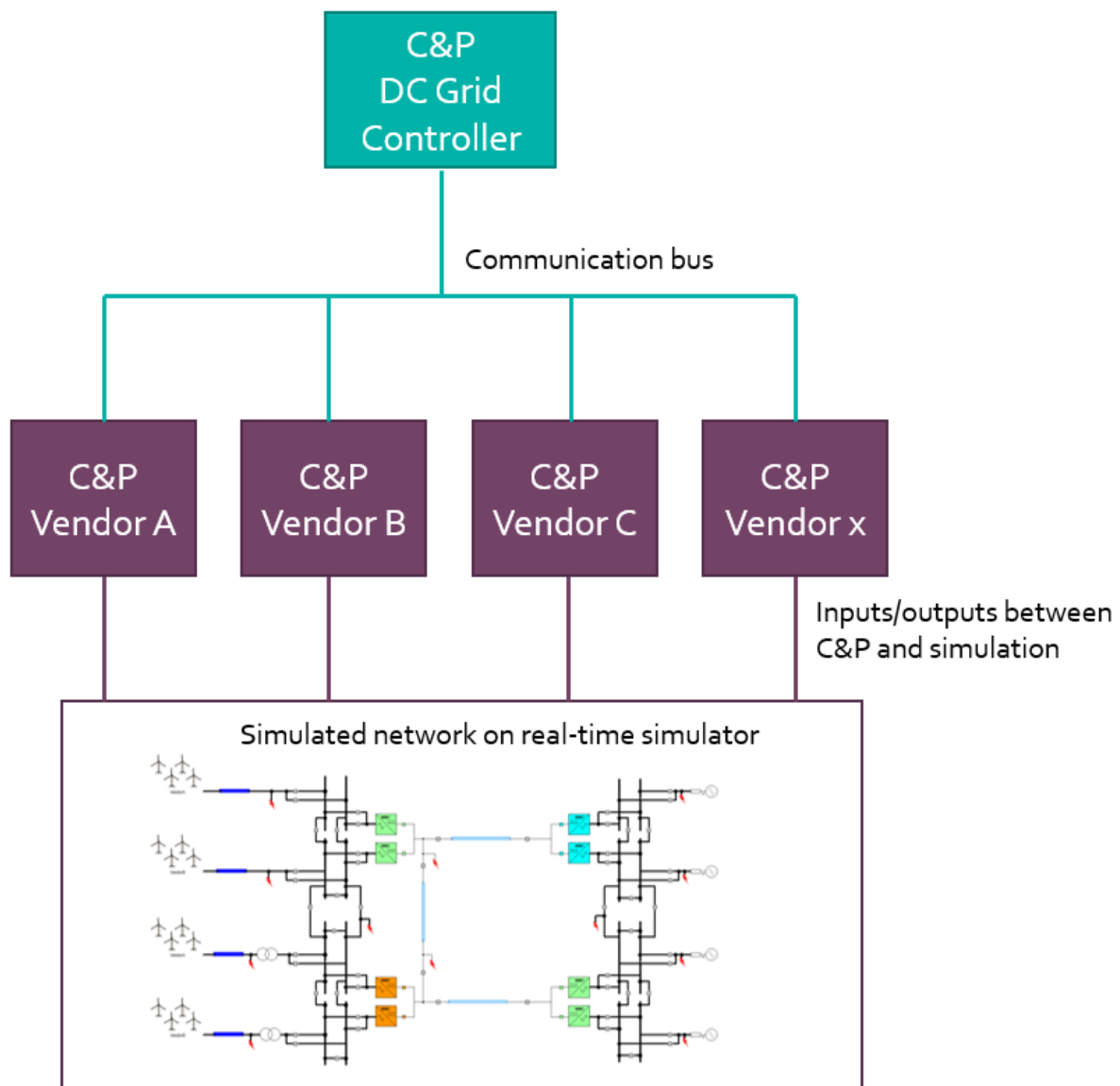

Figure 10 – Principle of the real-time simulation test setup

REAL-TIME 1.

Current requirement

For all the requirements below stated, any simplification proposed by the vendor for its system shall be duly justified and documented, with the differences and the consequences.

Examples

It can be for example:

- providing software in the loop instead of hardware in the loop,

- not providing all the hardware as on-site (simplify the auxiliary services control system, the cooling control system, no redundancy, etc.) *(for InterOPERA, "on-site" means considering state-of-the-art technology³⁵)*
- changing the hardware interfaces to adapt to the real-time simulator or to the external simulation platform,
- not providing all the protection relays
- simplifying the models to not represent effects that are not of interest for the interaction studies
- not performing Factory System Tests with the system integrator representatives
- etc.

Justification

This requirement is to remain result-oriented and to let some margin to the vendor to optimize the organizational aspects or to optimize the system by removing parts that are not of interest for the interaction studies context because it is not possible to define in advance the full list of possible simplification.

Documenting the simplifications aims at preventing the misuse of the system.

2.1.2 Preparation of the replica

2.1.2.1 Type of tests

REAL-TIME 2.

Current requirement

For interactions studies in InterOPERA, it shall be possible to perform the following tests in real-time, each test aiming at demonstrating the compliancy with the requirements *defined in WP2 and WP3*, and aiming at identifying potential adverse interactions (electromagnetic interactions, control interactions with near-by power electronic device, etc.):

- Energization – De-energization of the grid and all its components, using start and stop sequences³⁶, for example:
 - PPM
 - Converter station (from AC side and from DC side)
 - AC and DC lines
 - AC and DC cables
 - Unloaded power transformer
 - Busbar

³⁵ *In other words, the state-of-the-art means the solution that would be proposed to be delivered "on-site" if the InterOPERA project was a commercial project.*

³⁶ Energization and de-energization can lead to some prestrikes or restrikes, depending on the models and solvers used. Specific attention shall be paid to these phenomena to avoid incorrect conclusions.

- Tests to verify the behavior of the system in case of transients due to temporary or permanent, balanced or unbalanced AC or DC faults or due to an unexpected trip of a circuit breaker:
 - Protection coordination between all systems
 - AC protection
 - DC protection (*limited to WP2 and WP3 requirement in InterOPERA*)
 - If a trip is expected: the right system shall trip, and the robustness of the remaining grid and the recovery process are checked
 - If no trip is expected, correct behavior of the system during the fault and good recovery after fault clearing are checked
 - AC and DC FRT capability

The identification of the fault zone inside the model of each vendor is defined in specific chapters. The fine tuning of the protections for protection coordination within the provision of a given vendor is not part of the interaction studies.

- Dynamic performance studies: all the control functions involved directly or indirectly in the active power and reactive power management are tested to check their performance and the absence of interactions. For example:
 - Active / reactive power ramping
 - Frequency and voltage control
 - Load rejection
 - Emergency Power control functionalities
- AC grid forming capability studies
- Black start scenario studies (*to be noted that no black start scenario is currently expected in InterOPERA*)
- Transient studies due to AC or DC switching off- and on operation, activation of DC breakers, converter blocking phenomenon, slow-front transient overvoltage³⁷ and temporary overvoltage
- Sub-synchronous interaction studies
- Harmonic stability studies (assessment of harmonic impedance of converters and test of mitigation techniques), up to 2.5 kHz.
- Other stability studies
- Impact of the control location of each provision on the previous studies (control from local HMI or from the DC grid controller), within the limit of each control location.
- Impact of the loss of telecommunication on the previous studies.

Justification

The purpose of the tests is to assess the compliancy with the requirements. Therefore, the tests are performed in the limit of the requirements.

The initial target is to align the frequency range between offline and real-time. However, independently from the decision that can be taken for the models to extend the validity range above 2.5 kHz, in real-time, the harmonic stability studies are limited to 2.5 kHz to be able to fulfill the real-time constraint.

³⁷ The slow-front transient overvoltages to be considered shall be aligned with the time step of the real-time simulator.

Level of maturity

During InterOPERA, the balance cost/benefit of performing harmonic stability studies up to 2.5 kHz shall be assessed, as this frequency range could seem high and could require additional resources for vendors. The limits will be explored.

2.1.2.2 General description of the provision

REAL-TIME 3.

Current requirement

The provision shall consist of:

- the representative control, protection and communication functions to perform all the tests listed in REAL-TIME 2, these functions running with the same hardware, firmware, software and configuration as on-site (*for InterOPERA, "on-site" means considering state-of-the-art technology*).³⁸
- The representative model of the electrical and mechanical components that are interfaced with the control and protection functions above mentioned. More details are given in 2.1.3.1.
- A potential additional simulation platform. More details are given in 2.1.2.4.

REAL-TIME 4.

Current requirement

All the necessary input/output signals (with the RTS and/or with third-party systems) to permit a correct behavior of the system for the tests shall be provided.

REAL-TIME 5.

Current requirement

There is no need to establish interfaces for certain input/output signals in the system if these signals do not play a role in the testing process.

Example

Input/output signals from the valve cooling system that are not used for interaction tests shall not be interfaced. They will remain with an "unknown" status in the system; or if they are in a dedicated system, it is accepted that this dedicated system is not present and that the signals are not present at all.

Information

³⁸ The similarities with the on-site system explain why the term "replica" is often used in the literature and sometimes in this document.

The signals not relevant for the tests still exist in the system, as it is the real system. It is just that it is not necessary to connect these signals to input/output signals. Unused inputs signals can remain with an “unknown” status in the system. Unused output signals will simply not be used.

REAL-TIME 6.

Current requirement

Each C&P system shall be provided with the appropriate HMI and software to use the system, for the system integrator to be able to perform all the tests. It includes at least:

- (1) the operator HMI to operate the system.
 - (a) *A time-stamped event list shall be available on this HMI to follow the different events observed by the system.*
 - (b) *This event list shall be available in readable text format (such as .csv), and can be retrieved either using USB stick or any other mean.*
- (2) the engineer software to access specific settings, variables that would have to be changed for the tests.
- (3) *The possibility to force signals status on the external communication network (e.g., with the DC Grid controller) for communication test purpose is highly recommended.*
- (4) *The possibility to get around interlocks that are based on signals coming from a third-party system (for example, the DC Grid controller).*
- (5) *The tools and licenses to update the control and protection system according to the different topologies to be tested, as defined in WP3. It shall be feasible in a reasonable amount of time, for phase 2 to be of interest.*

Justification

(1a), (1b), (3) and (4) sentences have been written in italic “InterOPERA specific” because this is usually part of the functional requirements applying to the “real” system to be installed on the commercial site and it is not necessary to specify it for the replica, which simply inherits these characteristics. It is not an additional requirement specific to interaction studies.

(4) The request for interlocks override is necessary to prevent the system integrator from being fully blocked due to a bug (ex: a system does not provide the right information at the right moment to another system, and this is blocking the possibility to send a command from this system).

(5) The request for tools and licenses is for the system integrator to do the update, this is important in InterOPERA to prepare for each topology.

This request has advantages and disadvantages:

- Advantages in InterOPERA: it is easier from an organizational point of view if the system integrator can change autonomously.
- Disadvantages in InterOPERA: it means that training for that is required.

Consequently, as a “simplification”, if vendors prefer not to provide the tools and licenses, it means that it will be up to them to update the system. It might be harder to organize: is it doable from remote access or does it require physical presence?

In any case, the system integrator will optimize the test order to minimize the number of configuration changes.

This requirement is limited to InterOPERA due to the multi-topologies' context.

Maturity level

No fix limit of time is set for the moment to update the system:

- How to define a limit of time, as it depends on the human resources (experience and number)?
- What would be the limit?

The request for tools and licenses for the update shall be assessed for real project.

REAL-TIME 7.

Each C&P system shall be provided with a synchronization system, having the appropriate performance for the tests. *Time stamping of all signals shall be done at the source (i.e., by the controller that sends the data).*

Information for InterOPERA

The expected synchronization system is a GPS or GNSS clock. There shall be one clock provided by the vendor per integration lab. Other possibilities can be discussed and agreed with each system integrator. For example, TU Delft has a system connected to an atomic clock located at the NMI, that can distribute the synchronization.

For the DC Grid controller, it is expected that the GPS will be configured to act as PTP or NTP server, depending on the expected performance that will be defined in WP2.

How to use this requirement for commercial projects

Sentence regarding time stamping has been written in italic "InterOPERA specific" because this is normally part of the functional requirements. Indeed, it applies to the "real" system that shall be installed on the commercial site; and this characteristic shall be simply inherited by the replica. It is not an additional requirement specific to interaction studies. It is therefore recommended to check that the time stamping at the source is described in the functional requirements.

REAL-TIME 8.

Current requirement

Each C&P system shall be provided with a solution to record the behavior of the system during the tests, like for example a TFR - Transient Fault Recorder. This solution shall be usable autonomously by the system integrator.

The associated HMI, to use the TFR, shall be provided.

The records shall have an appropriate duration, precision and list of signals recorded (minimum list is given in the dedicated subsections) to enable the analysis of the tests.

Unless the solution provides permanent recording, it shall be possible to start a record based on detection of abnormal situation and based on signals coming from the RTS.

It shall be possible to configure the duration of the record before and after the trigger, with a total minimum record of 500 ms before the triggering signal and:

- For short events, 5 s after the triggering signal, with high-frequency sampling (range of dozens of kHz or the real sampling of the signal if below this range)
- For long events, 5 min after the triggering signal, with low-frequency sampling (>1 kHz).

If different level of accessibility of the signals shall be considered to provide records to other recipients than the system integrator (for example, record with more signals for analysis by the vendor itself, or on the contrary, record with less signals, which can be shared with other parties³⁹), then the vendor shall provide a solution, such as a second TFR or a script to edit the files by removing some signals.

Justification

Transient fault recording is generally not part of the core functions of real-time simulators. Even if they can record some signals, their performances are limited. Hence, a real-time simulator would not be able to record all the signals of all the systems in large projects such as InterOPERA.

Consequently, it is requested that each vendor provides its own solution for signal record.

The duration of the record will be adjusted according to the lessons learnt in InterOPERA.

REAL-TIME 9.

Current requirement

The vendor shall inform the system integrator about the real-time simulator (hardware, software), the solver and the time step used at its facility to test its system.

The vendor shall be aware that another real-time simulator and/or another solver and/or another time step can be used by the system integrator. In particular, depending on the real-time simulator to be used and on its solver, time steps between 2 and 40µs can be defined by the system integrator. In case of unexplained issues are detected by the system integrator, a discussion shall take place between the system integrator and the vendor.

Justification

Usually, a vendor tests its system for one simulator, one solver and one time step. The performances obtained in that context are considered as the reference if the system is used in another simulation environment.

Therefore, the system integrator needs information about this reference:

- to perform a benchmark in standalone in case the simulation environment is changed, to check that the performances are similar to the reference,

³⁹ These other parties can be different from the third-party mentioned for the communication's purpose.

- to be able to choose the best time step, considering all the vendors' preference.

So far, based on previous lessons learnt, when using the same real-time simulator and solver, the chosen time step to accommodate all vendors was not very far from the initial time step, and only limited differences were observed.

The system integrator is responsible for choosing an appropriate time step in accordance with the RTS and the solver used. It shall consider the validity domain of this simulation environment and its limitation when performing test and drawing conclusion.

It would be appreciated if the vendors could test their system not only with one time step but for a range of time steps (within the validity area of the solver). But as this means additional work for the vendor, this is not made as a requirement yet.

2.1.2.3 Lab constraint and EHS related to the preparation of the replica

Information

In InterOPERA project, there are two system integrators and two real-time labs: RTE and TU Delft labs.

How to use this set of requirements for real project

This paragraph must be adapted by each system integrator depending on its constraints and on the lab requirements described in the deliverable D1.2. Here is the frame of items that shall be defined during the call for tender, for items having an impact on the bidding, or at a later stage for details. If the system owner is different from the system integrator, the system owner shall manage the coordination between the system integrator and the vendor. Annex 1 can be used as an example to support the technical coordination between the system integrator and the vendor. The contractual coordination shall be discussed in WP4/WP5 of the InterOPERA project.

For their good installation in the lab, the replicas shall be prepared considering the following requirements.

REAL-TIME 10.

Current requirement

The cubicles shall fulfil the following requirements:

Requirement	Value for TU Delft	Value for RTE
Maximum height of the cubicles	2.5 m	2.5m
Maximum density of weight of the cubicles	500 kg/m ²	600 kg/m ² (*)

(*) : this value corresponds to the false floor constraints. If the weight per area is greater than this value, the cubicles shall be installed on a metal base with feet of adjustable height, to have the height adjusted to be on the same level as the false floor. In this case, the vendor shall provide the metal base.

REAL-TIME 11.

Current requirement

The cubicles shall guarantee the safety of goods and people over their entire lifetime, considering the physical risks (sharp edge, risk of falling) as well as electrical risks (earthing, safety against touch voltage, good insulation of the low voltage cable connections).

Information

The design of the earthing shall be discussed more in detail between the vendor and the system integrator at a later stage.

REAL-TIME 12.

Current requirement

The cubicles and their interior, with all their equipment, shall have at least an IP (Insulation protection) index equal or greater to IP2X. The mounting of isolated physical protection which requires tooling for installation/removal is required to prevent people from accessing involuntarily the non-IP2X parts if any.

Justification

This requirement comes from the French standard UTE C 18-510: IP2X or equivalent physical protection is for safer operation within the cubicles.

REAL-TIME 13.

Current requirement

The cubicles shall be adapted to planned cables' corridor in the lab:

- *RTE : entrance at the bottom of the cubicles*
- *TU Delft: entrance at the bottom of the cubicles*

REAL-TIME 14.

Current requirement

On the system integrator's request, the vendor shall consider the possibility to install the HMIs in a control room different from the cubicles room, with the associated workstations installed either in the cubicles room or in the control room. In such case, the vendor shall provide cables according to the length communicated by the system integrator.

For RTE, this option is chosen, and the maximum length is 45m ().*

(*): In any case, this requested maximal length requested cannot exceed the cable and network limitations.

Justification

RTE approach is that for easier testing, to operate all the systems at the same time, it is recommended to have all the HMIs close to each other, and consequently they can be distant from the C&P cubicles.

For RTE, there is a preference to have the workstations not installed in the control room but workstations in the control room are accepted if the generated heat and noise are low.

TU Delft approach is based on another solution, using remote access (see REAL-TIME 67). Consequently, TU Delft planned for the HVDC converter station vendors to put their HMIs in separate rooms. The other vendors (Vestas, SciBreak, and Siemens Gamesa) and SuperGrid Institute can put their cubicle(s) in the RTDS room or basement (their needs/requirements need to be discussed with TU Delft technician). With this design, the length between the cubicle and HMI is accordingly short.

REAL-TIME 15.

Current requirement

For the power supply, the vendor shall consider the following maximal length for the provision of cables between the distribution board and the cubicles:

- *TU Delft: 5m (*) (between every socket and the cubicles. The power supply cables between every socket and distribution board are supported by TU Delft)*
- *RTE : 10m (*) (length between the power supply sockets and the cubicles; RTE being in charge of the cable between the distribution board and the power supply sockets near the cubicles. One socket per circuit breaker in the distribution board is considered)*

(*): In any case, this requested maximal length requested cannot exceed the cable and network limitations.

REAL-TIME 16.

Current requirement

The following power supplies (*not secured by UPS*) are available:

Type of power supply	<i>TU Delft</i>	<i>RTE</i>
AC power supply	<i>230 V AC</i>	<i>230 V AC</i>
DC power supply	<i>110 V DC</i>	<i>125 V DC</i>
Provision of RCCBs in the distribution box	<i>Yes</i>	<i>Yes</i>

REAL-TIME 17.

Current requirement

For the workstations, EU plugs are expected:

- *RTE : type E*
- *TU Delft : type F*

Information

Here the type is defined, but for the male part, recent plugs are compatible with both E and F female plugs.

Maturity level: this requirement could be completed in the future to also request for local keyboard as it is more practical for the system integrator.

REAL-TIME 18.

Current requirement

For the power supply of the cubicles, CEE plugs will be made available by RTE.

For TU Delft, in case of 3 phases ceeform is forecasted, and in case of single phase, it can be ceeform or schuko plug.

REAL-TIME 19.

Current requirement

The vendor shall define the number of feeders, and their characteristics at least one year before commissioning of the system.

Justification

The one-year period is set for the system integrator to have the time to prepare the distribution board and reinforce the circuit if necessary.

REAL-TIME 20.

Current requirement

The vendor shall apply the relevant measures to protect both its software and hardware covered by an Intellectual Property, that takes into consideration the lab environment.

Example

Relevant measures can be for example closed cubicles so that the hardware does not show, automatic screensaver after a certain delay without any action on the HMI and a password to protect the access to the system from the HMI.

Information

This requirement is reflected in WP4.

2.1.2.4 External simulation platform

REAL-TIME 21.

Current requirement

The vendor shall consider that system/components not necessary for the computing of voltages and currents at the point(s) of coupling, considering interaction studies framework, are not included in the RTS.

For example, the following system/components are not included in the RTS:

- Electrical components always operated without voltage, such as the earthing switches to reach the Earth state
- Cooling system
- Auxiliary system.

Justification

This is to not slow down the RTS.

REAL-TIME 22.

Current requirement

With reference to REAL-TIME 21, the vendor shall provide a simulation platform to simulate all inputs/outputs necessary for the operation of its system in case it needs inputs and outputs not included in the RTS.

For switches that are part of the main circuit, the electrical behavior is part of the RTS. However, the position feedback can be provided by the RTS or not, depending on the manufacturer's need.

Justification

For real project, the replicas are required to use the same code as the one that is installed on site. In this code, there might be interlocks, functions, process linked to components that are not simulated on the RTS; and this might prevent a smooth operation of the system for testing (for example, for HVDC converter station, the system can't start if the cooling is not operational).

REAL-TIME 23.

Current requirement

The simulation platform shall include automatic logic to provide automatic feedback to the commands sent by the C&P system, if required by the C&P system.

Example

This is for example the feedback of the position of a disconnector that is not modelled on the RTS.

Justification

The purpose is to avoid problems such as a sequence failure.

REAL-TIME 24.

Current requirement

The simulation platform shall include the possibility for the user to manually change the outputs from the simulation platform to the C&P system.

Justification

This is to be able to simulate troubles that are useful to test the logic and robustness of the system in degraded mode, i.e. to perform tests with a system that is not perfectly and entirely operational. One can imagine for example a cooling capability reduction, limiting the power to be transmitted by the converter station.

REAL-TIME 25.

Current requirement

In InterOPERA, it is not requested to consider the cooling system and the auxiliary system that is usually interfaced with the C&P system.

Justification

The purpose is not to force the vendor spending extra time on developing a cooling system and an auxiliary system in InterOPERA, as it will not be useful for the interaction tests. However, if it is easier for the vendor to keep an existing piece of code, that already includes the cooling system and the auxiliary system, this is possible.

It is worth noting that the assumption done here, is that no specific information related on the auxiliary system and the cooling system will be transmitted to the DC Grid Controller. If a fault occurs on the auxiliary system or on the cooling system and has a certain consequence, it is expected that only information related to this consequence (without consideration of its cause) will be sent to the DC Grid Controller. For example, it can be a reduction of the maximum power capability.

2.1.2.5 Interfaces with the RTS

REAL-TIME 26.

Current requirement

The C&P system shall use non-proprietary interfaces from the following list:

- Hardwired inputs/outputs signals (up to +/- 10 V for analogue signals, from 5V up to 24V for binary/digital signals)
- IEC 61850 interface for sampled values, GOOSE and MMS
- TCP/UDP
- DNP3
- Modbus

- IEC 60870-5-104
- IEEE C37.118
- Aurora protocol
- EtherCAT – the RTS being slave ⁴⁰

Justification

This list is based on the common list of interfaces for RTDS and HYPERSIM.

Maturity level

This list shall be regularly checked to remain always up to date as it is technology-dependent. It might evolve during InterOPERA.

REAL-TIME 27.

Current requirement

For RTE, for InterOPERA specific project, the vendor shall provide a solution to connect hardwired signals to one simulator or to another, exclusively, using connectors.

Justification

This solution shall prevent an inadvertent connection in parallel to both simulators because it can lead to damages.

This is specific to InterOPERA where RTE will use both RTDS and HYPERSIM.

REAL-TIME 28.

Current requirement

For RTE and TU Delft, place shall be forecasted in the vendor cubicles for the integration of RTDS I/O cards provided by the system integrator. The integration is done by the vendor, including the power supply of the cards.

How to use this requirement for real project

This requirement shall be assessed on a case-by-case basis and shall be coordinated with the system integrator and the vendor during the call for tender to determine the optimum solution.

REAL-TIME 29.

Current requirement

⁴⁰ This is currently under development and shall be ready in a few months following the publication of this paper.

For RTE, for HYPERSIM, for hardwired signals, DB37 female connector shall be used. If there is place remaining in the cubicles, the integration of HYPERSIM rack with the I/O shall be proposed by the vendor.

How to use this requirement for real project

This requirement shall be assessed on a case-by-case basis and shall be coordinated with the system integrator and the vendor during the call for tender to determine the optimum solution.

2.1.2.6 Interfaces with other equipment

REAL-TIME 30.

Current requirement

The interface for the communication network (for grid coordination) is located at the C&P system interface of vendors for AC/DC converter stations, wind power plant and DC switching stations.

This corresponds to the connection point between the communication cable, represented in green on Figure 10, and the C&P system represented in purple on the same figure.

How to use this requirement for real project

In InterOPERA, the communication network is in the scope of supply of the DC Grid Controller (see REAL-TIME 33). If the communication network is not in the scope of supply of the DC Grid Controller, then this requirement shall also be applicable to the DC Grid Controller, with the difference that Figure 10 shall be updated with different colors between the communication network and the DC Grid controller itself, and the interface would be between both.

REAL-TIME 31.

Current requirement

This interface shall be compatible with multimode LC connector, duplex; and shall support 1000BASE-SX (IEEE 802.3z standard).

Justification

This is to make sure that it will be possible to connect easily all the systems together in InterOPERA.

Maturity level

This requirement shall be discussed for commercial projects. Indeed, for commercial projects, similar routers as on-site are expected. These routers are usually connected to telecom device using Dense wavelength-division multiplexing or Synchronous Digital Hierarchy technology and the interface is managed at that level and is not necessarily the same everywhere. As these telecom devices are not present at the labs, the routers will have to be connected to another system. In that case, who is

responsible for potential additional device to ensure the compatibility between the router and the other system: the system integrator or the vendor?

REAL-TIME 32.

Current requirement

UTC+0 shall be used as the reference for the time stamping in all communications.

Justification

This is to make sure that communication is not rejected due to unexpected too long delays if the time reference is not the same.

For commercial projects, this shall be managed by the functional requirements for the on-site system. Therefore, no additional requirement shall be defined for the replica.

REAL-TIME 33.

Current requirement

The cable to connect the communication network to the equipment designated by the vendor, represented in green on Figure 10, is in the scope of supply of the DC grid controller.

Justification

This is specific to InterOPERA and reflect the consortium proposal.

How to use this requirement for commercial projects

For commercial projects, the responsibility for the communication network between each vendor's system shall be allocated to "someone". This "someone" is not mandatorily the DC grid controller. It could also be the system integrator or any vendor.

2.1.2.7 Documentation

REAL-TIME 34.

Current requirement

At this stage, and at least 1 year before replica Factory System Test (FST), simplified and preliminary interface document shall be provided describing:

- the number and type of I/O and the number of licensed cores.
- The layout of the cubicles (size and number of cubicles, doors' characteristics, if specific cubicles have to be placed side by side, how the earthing of the cubicles is achieved, power supply, connection point for the remote access))

Justification

This is for the system integrator to prepare the facility and to purchase the RTS.

2.1.3 Internal tests at vendor's lab and Factory System Tests preparation

REAL-TIME 35.

Current requirement

Before delivering the cubicles at the lab, the vendor shall perform internal testing to ensure that the system is ready for performing the tests described in 2.1.2.1.

2.1.3.1 Power circuit modelling

REAL-TIME 36.

Current requirement

The vendor shall prepare a real-time model for the electrical components of its system (e.g. the DC switching station, the HVDC converter station, etc.) for those internal tests and for factory system tests of the system. The model shall be compliant with the requirements below stated:

- The electrical devices models shall be prepared as open box (such as public library of the simulation tool), except for MMC converter valve model (refer to 2.5.2)
- The recommendations written in [2] shall be used as a reference.
- They shall fit for the purpose of all the tests listed in 2.1.2.1.

Justification

This model will be needed by the system integrator to prepare the RTS. Open box is requested in case another RTS shall be used by the system integrator.

Information

If the system has no associated power circuit (such as the DC Grid Controller), then it simply means that no power circuit modelling shall be provided.

REAL-TIME 37.

Current requirement

All relevant electrical components in the scope of supply of the manufacturer shall be included in this real-time model, such as DC disconnecter, DC circuit breaker, power transformer, surge arrester, DC and AC reactors and filters.

REAL-TIME 38.

Current requirement

Non-electrical constraints/phenomena, having an impact on the electrical behavior at the point of connection, shall be considered.

Example

It can be the generator inertia, the representative effect of the pitch control (*limited to the effects due to WP2.1 functions*)

Information

Currently, this requirement is mostly relevant for PPM. But this requirement is written as a common requirement to consider potential new technology for any system.

2.1.3.2 Preparation of FST

REAL-TIME 39.

Current requirement

During this internal testing period, to prepare for the Factory System Tests (FST),

- the list of FST tests shall be provided to the system integrator at least **2** weeks prior to carrying out these tests during the final internal testing phase, with sufficient accuracy to ensure repeatability (ex : fault types, location, relevant parameters)
- the real-time model used on the RTS shall be provided to the system integrator at least **2** weeks before FST
- the results of the tests shall be shared at least **1** week before FST. Test reports shall include the reference to the description of the test case and files for the graphs (ex : COMTRADE file), list of event,...

Justification

This is for better preparation and higher efficiency during FST: the system integrator is already familiar with the expected results and know what to test during FST. And thanks to the delivery of the real-time model, the system integrator will have the possibility to prepare its own RTS, in case its RTS is to be used during FST.

How to use this requirement for real project

The indicated delays shall be adapted on a case-by-case basis, as they depend on the number of tests to be reviewed and on the system integrator's constraint to prepare for the FST.

REAL-TIME 40.

Current requirement

The FST list shall include enough tests to use all input/output signals of the C&P system with the RTS, while the RTS is running a simulation of the associated electrical component in real-time.

Justification

Purpose of the C&P system FST is not to check the dynamic performance of the C&P system, but that the system can be correctly interfaced with the RTS to be able to perform the dynamic performance tests later on.

REAL-TIME 41.

Current requirement

If deemed necessary, the vendor shall request at least one year before testing phase that the system integrator provides the RTS (computation unit and/or interface cards) for the tests.

Justification

One year is a conservative delay, for the system integrator to have enough time to order the hardware and have it delivered to the vendor's facility.

REAL-TIME 42.

Current requirement

The list of FST tests shall also include enough tests to use all input/output signals with the third-party system(s) using the communication network. For that purpose, the vendor shall include a protocol emulator in its simulation platform for point-to-point test.

Justification

These tests are necessary as the communication is part of the interaction tests to be performed. The protocol emulator will emulate the communication with the third-party system(s).

2.1.4 System integrator's training

REAL-TIME 43.

Current requirement

The system integrator shall be trained by the vendor for the use of its system.

REAL-TIME 44.

Current requirement

This training will be done during FST phase and during the commissioning phase. *Additional training session before FST phase shall be proposed by the vendor on the system integrator's request, with maximum duration of one week.*

Information

Conditions for training are project specific and shall be discussed on a case-by-case basis.

REAL-TIME 45.

Current requirement

The scope of the training shall be:

- The presentation of the main hardware of the system and the connections
- The presentation of the main software of the system
- The presentation of the HMIs (operator, engineer, TFR, external simulation platform) and how to use it
- The presentation of the main functions included in the system
- The presentation of the main maintenance tasks.

2.1.5 Factory System Tests at vendor's lab

REAL-TIME 46.

Current requirement

Before delivering the cubicles at the lab, and after internal testing, the vendor shall perform Factory System Tests (FST), in the presence of the system integrator's representatives, for them to witness that the system is ready for performing the tests described in 2.1.2.1.

Justification

It is better for the system integrator to witness that the system is ready before shipping the cubicles, because, in case of troubles, it is easier for the vendor to correct them when the cubicles are still at the factory. This quality process shall ensure reduced commissioning time at the lab.

REAL-TIME 47.

Current requirement

During the FST, all the normal operator actions to perform the tests shall be performed from the operator HMI. When special settings shall be accessed, the appropriate HMI shall be used (e.g., the engineer HMI).

Justification

The operator HMI is used for user-friendly use of the system, for higher testing efficiency. Other HMI can be used because not everything is accessible from the operator HMI.

REAL-TIME 48.

Current requirement

The duration of the FST phase shall be defined by the vendor in accordance with the complexity of the system.

Justification

No fixed duration is defined, as it depends on the complexity of the system. Concern might be about too short FST duration, but this risk is covered by the fact that it is not in the interest of the vendor to have this too-short duration: it is better to detect and correct issues at his facility, than at the lab.

REAL-TIME 49.

Current requirement

After completion of FST, if the system is considered ready to perform the tests stated in 2.1.2.1, according to the results of the FST tests, the cubicles can be dismantled and shipped to the lab.

FST reports are not necessary, except if different results are observed from already shared reports.

Justification

This requirement has been written in such a way that there is a tolerance for small bugs not impacting the use of the C&P system for the interaction tests.

To avoid double work with the reports requested in REAL-TIME 39, FST reports are limited to the case where different results are found.

2.1.6 Delivery and installation of the system at the real-time lab facility, lab constraints and EHS

Information

In InterOPERA project, the real-time lab facilities are RTE and TU Delft labs.

How to use this set of requirements for real project

This paragraph must be adapted by each system integrator depending on its constraints and on the lab requirements described in the deliverable D1.2. Here is the frame of items that shall be defined during the call for tender, for items having an impact on the bidding, or at a later stage for details. If the system owner is different from the system integrator, the system owner shall manage the coordination between the system integrator and the vendor. Annex 1 can be used as an example to support the technical coordination between the system integrator and the vendor. The contractual coordination shall be discussed in WP4/WP5 of the InterOPERA project.

Communication and mutual agreement between a system integrator and a vendor are necessary for all the activities to be performed in the lab, for example regarding the planning, delivery, installation and commissioning.

REAL-TIME 51.

Current requirement

Any person working in the lab, including the vendor and its subcontractors, shall comply with the local rules related to:

- the specific rules to allow people from other companies to work within the facility
- the work in an electrical environment. People shall have the relevant electrical accreditation, corresponding to its tasks.

For RTE, the standard NF C18-510 shall be considered. And the electrical work done by the vendor at the lab shall be performed under a permit to work given by the system integrator. This permit of work will be issued by RTE at latest one week after all required documentation was handed in. Specific documents can be requested by the system integrator to deliver this permit to work.

For the work that will be conducted at the TU Delft lab, vendors' technicians with work permit issued in one of the EU countries, will be introduced to the TU Delft representative who will take care of obtaining a work permit for TU Delft.

Justification

Government rules are supposed to be assessed by everybody, are publicly available and requirements do not come from the system integrator, and therefore, even if they are applicable, they are not mentioned in the document.

Some extra requirements which are requested by the system integrator should be mentioned in the document, for the vendors to prepare.

REAL-TIME 52.

Current requirement

During the whole period the system is installed at the lab, it is strictly forbidden for everybody to do any kind of reverse engineering on the hardware and software delivered by the vendors of the project.

Information

This requirement is reflected in WP4.

2.1.7 Commissioning of delivered cubicles at the real-time lab facility

2.1.7.1 Process

REAL-TIME 53.

Current requirement

The vendor shall install the cubicles at the lab and ensure that the wiring is correct.

Justification

Ensuring that the wiring is correct, is part of the quality process, to ensure smooth commissioning.

REAL-TIME 54.

Current requirement

The commissioning is performed jointly with the system integrator and the manufacturer.

REAL-TIME 55.

Current requirement

For the interface with the RTS, the list of commissioning tests is similar to the FST list.

Justification

Using similar tests to FST makes it possible to compare the results and check that everything is still working fine.

Maturity level

There is a pending open question: is it possible to reduce the number of required test? If the operation of all channels is proven, this is possible (because there shall be no software changes between FST and commissioning).

REAL-TIME 56.

Current requirement

Commissioning of the interface between the C&P system and the communication system is performed when both the DC grid controller and the C&P system are ready at the lab, with the presence of both vendors.

Justification

To have two systems communicating together for the first time is often a challenging step, with unforeseen issues. This is why it is important to have the presence of both vendors.

2.1.7.2 Documentation

REAL-TIME 57.

Current requirement

At this stage, the following documentation shall be provided for the system integrator's tasks:

- Layout of the cubicles (size and number of cubicles, doors' characteristics, if specific cubicles have to be placed side by side, how the earthing of the cubicles is achieved, power supply, connection point for the remote access))
- Interface signal list and wiring diagram between [the RTS, third-party provision] and [the system, the external simulation platform (if any)] with at least the following items of each signal, if applicable:
 - label
 - Description of the signal
 - Type of the signal (analogue, binary, digital)
 - Minimum and maximum value in case of analogue signal
 - Scaling factor of the analogue signal
 - Default state/status of the signal
 - Associated label of the signal in the event list
 - Reference of the signal in the single-line diagram
 - Connector PIN assignation of the signals

For communication using optic fiber, the type of optic fiber, type of connector, speed of the communication shall be given.

- List of all software installed, with their version, with:
 - The user guide of each software, in particular HMI guide, engineering software guide (if needed for actions to be performed by the system integrator) and TFR guide
 - Procedures for software update if update shall be performed by the system integrator
 - Specific guide if several configurations have to be loaded depending on the use case
- Description of the functions of the system (control, protection, telecommunication)
- Maintenance guide of the system (ex: how to restart the system after a loss of power supply in the lab)
- Training documents, if different from the user guides (e.g.: PPT file shared during training)
- Clear instructions shall be given for signal accessibility management: if needed for analysis, which signals can be shared with a third-party, how to get them?

Future requirement

For commercial projects, this list shall be completed with the wiring scheme of the cubicles.

Justification

This is for the system integrator to be autonomous for testing.

Information

The content of training documents will depend on the type of training to be performed (refer to 2.1.8 and 2.1.4)

2.1.8 After the commissioning

REAL-TIME 58.

Current requirement

To work in the lab without the presence of the vendor, a document that states the transfer of responsibility shall be signed by both the system integrator and the vendor.

This document shall precisely define the limit of responsibility for both parties.

Information

The content of the document shall be discussed in WP4.

2.1.8.1 Maintainability and updates

REAL-TIME 59.

Current requirement

For InterOPERA project, the vendor will be responsible for the maintenance of its system and for all the updates.

However, for the benefit of the project, it can be commonly agreed between the system integrator and the vendor that the system integrator performs some actions on the vendor's request and under its responsibility.

In such a case, procedures shall be provided by the manufacturer.

Future requirement

The vendor shall provide all the tools and documentation for the system integrator to replace the potentially faulty devices.

Justification

In InterOPERA, the cubicles are owned by the vendor. This is why the vendor is responsible for the maintenance of the system. The proposal for the system integrator to help has been made to lower organizational constraint and to reduce travel costs.

Maturity level

This requirement is not adapted to a commercial project and shall be re-written to consider potential warranty period, spare part management and any other item that is usually defined for maintenance contracts. However, this is normally part of the contract and not part of the technical specification. Hence, the proposal for future commercial project is not included in this document.

REAL-TIME 60.

Current requirement

The system integrator shall be able to shut down the power supply and repower and restart the system without the support of the vendor.

Justification

Based on previous lessons learnt, this is often an efficient solution in case of crash of the system; or to restart with a “clean” system, not polluted by previous tests, or in case of power supply shutdown (planned or unexpected).

REAL-TIME 61.

Future requirement *(not applicable in InterOPERA)*

The C&P system shall be updated every time the on-site system is updated in order to replicate the on-site situation. Alternatively, depending on the estimated risks, it can be requested to perform this update in advance, before the C&P system is updated at site, to perform interaction tests for de-risking the on-site update.

REAL-TIME 62.

Future requirement *(not applicable in InterOPERA)*

If it is agreed that the system integrator is in charge of updating the system(s), the vendor shall provide all the tools and documentation for the system integrator to perform this update.

REAL-TIME 63.

A document shall be delivered to explain the differences between the previous system version and the new system version and to list the non-regression tests⁴¹ to be performed to the vendor’s best knowledge to check this new system version.

REAL-TIME 64.

A version tracking document shall list all the updates and shall mention the associated identification number.

At any time, it shall be possible to know, for each equipment, which software, firmware, database, etc. versions are installed.

REAL-TIME 65.

⁴¹ Non-regression tests aim at checking that no issues have been introduced involuntarily in the system due to the changes. The tests that were previously successful shall remain successful. In other words, it demonstrates that there is no regression.

The documentation described in REAL-TIME 57 shall be updated according to the updates performed on the system.

2.1.8.2 Remote access

REAL-TIME 66.

Current requirement

An Internet access point is provided at the lab.

At TU Delft, the access is provided through a firewall and a VPN; or through "Citrix". Relevant information shall be provided by the manufacturer to TU Delft for the configuration of the VPN and for the configuration of the firewall. Regarding the workstation, nobody is allowed to use his/her own workstation with a connection to internal VLANs of TU Delft. Therefore, it is planned to create isolated VLANs for each vendor separately.

At RTE, the access will pass through a firewall to limit the authorized IP. The vendor shall provide the list of IP addresses for RTE to configure the firewall.

REAL-TIME 67.

Current requirement

If remote access is deemed necessary by the vendor, it is on its responsibility to:

- Provide the cable between the Internet access point and its system
- Secure this Internet access
- Install all the necessary software, both on the system at the lab and remotely.

In InterOPERA, additional remote access is requested by TU Delft. The vendor shall determine the appropriate level of access through this remote access according to the tasks to be performed remotely by TU Delft for the tests. If this level of access is different from the one of the vendor itself, the vendor shall manage that there can be several types of remote connections and shall consider at least one user for each type at the same time.

REAL-TIME 68.

Current requirement

The use of the remote access shall be coordinated with the system integrator. The vendor shall describe the actions it plans to perform, in particular if it has an impact on the availability of the system, to find a common agreement on the best time slot to perform these actions.

2.2 Requirements for hardware and software in the loop – specific to DC grid controller and communication system

2.2.1 Communication system

REAL-TIME DCGC 1.

Current requirement

It shall be possible to emulate delays on the communication system between DCGC and other controllers.

2.2.2 Signals for analysis

REAL-TIME DCGC 2.

Current requirement

It shall be possible to record all the communication between the DC Grid controller and the other systems for analysis purpose.

Maturity level

Here, it is only requested to record the communication. However, in WP2, the functions of the DC Grid Controller will be defined and access to internal signals might be requested for analysis. Consequently, depending on the outcomes of WP2, a possibility to record and export these internal signals might be defined in the future (this could be done with another file and another solution compared to the communication).

REAL-TIME DCGC 3.

Current requirement

In InterOPERA project, it shall be possible to collect data for a maximum of one day.

Maturity level

Recording duration is the function of the volume of data, linked to number of signals and time step.

One day is the first guess. It is long enough to avoid record loss in case of automatic testing at night. The duration might be adapted in the next release of the document, based on the lessons learnt. It shall be the best compromise between having the record long enough, for comfortable testing conditions, and short enough, for easier file processing.

REAL-TIME DCGC 4.

Current requirement

The data format could be simple files (csv) or more formalized database.

Information

It is possible to extract data from the database and to save them with different formats, including csv.

REAL-TIME DCGC 5.

Current requirement

The DC grid controller shall add a timestamp to all received signal.

Justification

It should be possible to check the communication layer performance.

2.2.3 Control system solution

REAL-TIME DCGC 6.

Current requirement

In InterOPERA, the DC Grid Controller shall be provided as hardware in the loop.

As a nice-to-have, it is proposed to provide it also as software in the loop, without the communication layer. In that case, two different pieces of software would be provided, one to be run on HYPERSIM using UCM and the other on RTDS GTSOC. It is accepted that the integration tests are only performed by the system integrator, and that the system integrator is responsible for the communication layer from the RTS to the other vendor's system.

Justification

This requirement was to reflect the consortium proposal which was originally focused on the HIL solution for the DC Grid controller. For the SIL, the responsibility of SuperGrid Institute in InterOPERA would be limited compared to what could be expected in another context, to keep the work and cost for SuperGrid Institute reasonable. The system integrator will compensate what cannot be done by SuperGrid Institute: the system integrator will provide the necessary hardware (for example, the GTSOC and GTNET cards), configure the real-time simulator accordingly and test the performance of the SIL.

2.2.4 Automatic testing functionality

Information

Generally speaking, the real time simulated multi-terminal multi-vendor (MTMV) Bipole VSC-HVDC network in WP1 will enable the proper digital representation of the offshore wind power transmission towards several AC-grid-connected onshore VSC-HVDC units. By considering this general approach, the

produced offshore wind power levels, and the associated DC power distribution among all the onshore VSC-HVDC units, represent two fundamental aspects that need to be defined to adequately establish the steady-state power flow conditions within the real time simulated MTMV Bipole VSC-HVDC network in WP1.

The two fundamental aspects described in the above paragraph are expected to be tackled within the dispatch-level hierarchy (i.e., the AC/DC Grid Control) of the real time simulation (RTS) platforms. In that sense, SuperGrid Institute has clarified that the AC/DC Grid control is going to be developed as a Human Machine Interface (HMI) software which will be installed on Auxiliary PCs of the corresponding Simulation Labs. Furthermore, it is also expected that the HMI is going to be primarily utilized by an operator intended to alter the steady-state power flow conditions within the real time simulated MTMV Bipole VSC-HVDC network.

Therefore, in InterOPERA, an ATF (Automatic testing functionality) can be used to facilitate the tests. It represents an embedded feature in the HMI that shall facilitate the operator's work by allowing consecutive changes of the steady-state power flow conditions during the real time simulated MTMV Bipole VSC-HVDC network.

It is agreed to not request to send commands to stop and start the converter stations through the ATF in order to keep the ATF simple.

REAL-TIME DCGC 7.

Current requirement

The ATF shall be implemented within the HMI and activated / deactivated by the HMI operator.

REAL-TIME DCGC 8.

Current requirement

The minimum time frame for each steady-state power flow condition (defined by the HMI operator) shall be 30 s.

Justification

It is not expected to send power flow set points more frequently than every 30 s. 30 s is sufficient to reach the steady-state in the system and then move to another steady-state to reflect a change in the electricity market with new power flow setpoints.

REAL-TIME DCGC 9.

Current requirement

The ATF shall allow to the HMI operator to modify the time frame for each steady-state power flow condition up to maximum of 1 hour (minimum requirement).

Justification / Maturity level

1h is proposed in order to have more time to perform different studies with the same conditions. If not possible, one can choose to duplicate a 30 min step with the same values.

REAL-TIME DCGC 10.

Current requirement

The ATF shall support up to a 100 consecutive changes of the steady-state power flow conditions within the real time simulated MTMV Bipole VSC-HVDC network.

Justification

100 steps have been proposed, by considering the evolution of the electricity market up to 15 minutes time slots. In that case, 100 steps correspond to approximately one market day.

REAL-TIME DCGC 11.

Current requirement

In total, the ATF shall support up to 8h automatic testing (i.e. for example maximum 8 steps of 1 hour each, or 100 steps of about 5 minutes).

Justification

This requirement is to avoid having 100 steps of 1 hour each, which would mean 100 hours of test.

REAL-TIME DCGC 12.

Current requirement

If applicable, the ATF shall allow the modification of the power set points calculated by the DC CG for the offshore PPMs connected to the MTMV Bipole VSC-HVDC network.

Information

By “if applicable”, it is meant that the user can choose to give a power set point to the PPM, or to let the DC Grid Controller optimize. The user shall not be forced to fix a power set point.

REAL-TIME DCGC 13.

Current requirement

The ATF shall allow the modification of the active power set points in those onshore converter unit/substations operating in PControl.

Example :

*A practical understanding of the ATF can be developed as soon as a concrete example is discussed. For that reason, let's imagine three different offshore PPMs connected to a multi-terminal HVDC network, and three onshore converter substations connecting this multi-terminal HVDC network to three corresponding AC networks. Now, let's assume that only **two** of these onshore converter substation are defined to operate*

under the $P_{Control}$ mode. Therefore, the operator of the HMI should at least be capable of establishing the corresponding power of the three offshore PPMs and the two onshore converter substations as shown by Table 1:

Table 1 - Example of Basic Power references defined by the HMI's operator.

Offshore PPMs Generation			Onshore Converter Substations using $P_{Control}$ mode	
$P_{OWF\#1}$ (MW)	$P_{OWF\#2}$ (MW)	$P_{OWF\#3}$ (MW)	$P_{ONS_Sub\#1}$ (MW)	$P_{ONS_Sub\#2}$ (MW)
500	500	500	600	600

Thus, the ATF can be seen as an extension of Table 1 where several steady-state power flow conditions (SSPFC), and their associated time duration are included as shown in Table 2.

Table 2 - Example of Basic Power references defined by the HMI's operator using the ATF function.

SSPFC	Duration (s)	$P_{OWF\#1}$ (MW)	$P_{OWF\#2}$ (MW)	$P_{OWF\#3}$ (MW)	$P_{ONS_Sub\#1}$ (MW)	$P_{ONS_Sub\#2}$ (MW)
1	120	500	500	500	600	600
2	60	150	150	150	400	400
3	90	1000	0	1000	1000	500

By looking into Table 2, it can be seen that the SSPFC 1 is meant to last for 120 s, and right after, the power dispatch levels associated with SSPFC 2 are going to be sent (by the HMI) to the corresponding DC Grid Controller for the next 60s. After this 60s, the power dispatch levels associated with SSPFC 3 will be sent to the DC Grid Controller for 90s, and they will indefinitely remain at those levels after that time.

REAL-TIME DCGC 14.

Current requirement

It shall be possible to import and export the table used for the ATF (for example as a .csv file).

Justification

This comes on the top of the possibility to directly edit the table in the HMI.

2.3 Requirements for hardware in the loop – specific to DC Switching station

2.3.1 Control and protection required functions

REAL-TIME DCSS 1.

Current requirement

To evaluate the need for protection during the tests, the principle defined in OFFLINE DCSS 4 shall be considered.

2.3.2 Internal signals to be accessible and recorded

REAL-TIME DCSS 2.

Current requirement

At least, the signals defined in OFFLINE DCSS 7, coming from the control and protection system itself, shall be accessible and recorded, considering REAL-TIME 8.

Maturity level

This is a first proposal. The list could evolve during InterOPERA, with the lessons learnt.

2.4 Requirements for hardware in the loop – specific to PPM

2.4.1 Control and protection required functions

REAL-TIME PPM 1.

Current requirement

To evaluate the need for protection during the tests, the principle defined in OFFLINE PPM 6 shall be considered.

REAL-TIME PPM 2.

Current requirement

In InterOPERA, the scope of supply of the vendor consists in the provision of the PPC, the WT as well as the communication between them. The model of the main grid transformer, the collecting grid, their control and protection will be provided by the system integrator.

In Figure 11, the blue blocks represent the power level of the wind turbine, up to the coupling point with the grid collector. This power level can be simulated on the real-time simulator belonging to the system integrator, or can be totally or partially simulated on another solution provided by the vendor, in the conditions defined in REAL-TIME PPM 4.

The pink blocks are provided as hardware in the loop. They can be provided as software in the loop in the conditions defined in REAL-TIME 1. Only "main" blocks are defined here, it does not presume of the content of the blocks, each block being made of several blocks as defined in the IEC 61400-21-5.

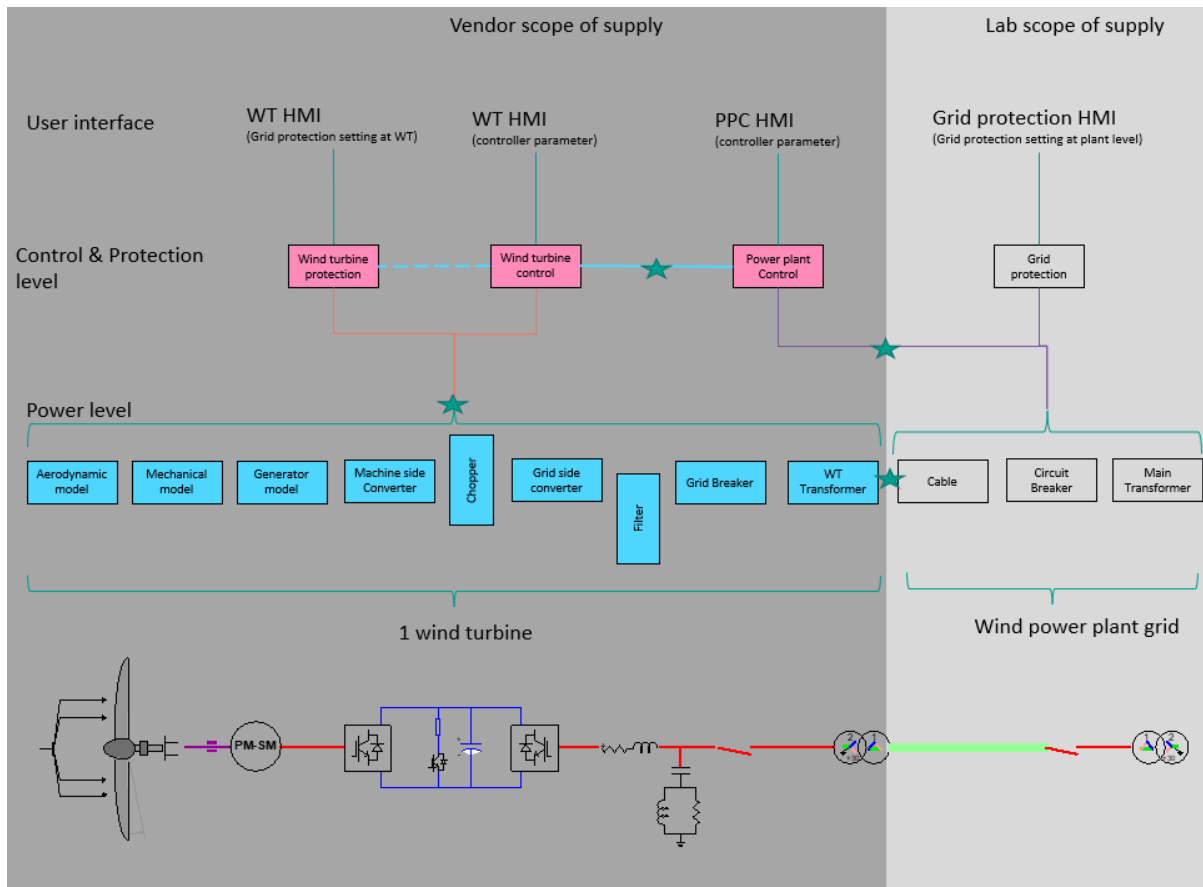

Figure 11 : Limit of scope of supply between the system integrator and wind turbine vendors in InterOPERA (illustrated here with only one WT)

Each vendor shall provide 2 PPMs per lab for the real-time simulation.

To consider the multiple topologies described in WP3, it shall be possible to configure each PPM as a 500MW PPM or as a 1GW PPM.

Information

Another limit of scope of supply can be defined for commercial projects. For example, the grid collector model, or part of it, can also be modelled by the vendor and be simulated on an external simulation platform, in the same conditions as REAL-TIME PPM 4.

REAL-TIME PPM 3.

Current requirement

For one PPM, there shall be:

- Enough WT C&P modules, considering the possibility of aggregating all the WTs belonging to the same control group in the PPC. This possibility, if chosen, is under the responsibility of the vendor.

- Enough PPC module to manage the PPM.

Example

If one PPM has a total power of 500MW, with one PoC, vendors shall check if it is possible to aggregate all the necessary WT and to use only one WT C&P module and one PPC module.

Maturity level

Aggregation per string or no aggregation within one string or no aggregation at all (first 3 cases in Figure 12) are not requested in InterOPERA for real-time.

Only aggregation at PPC level is proposed here (last case in Figure 12, if one PPC is sufficient for the PPM) to limit the hardware to be provided in InterOPERA.

However, for commercial projects, if the vendors apply aggregation, it shall be justified by simulations and comparison between offline and HIL that this is applicable. Indeed, the conclusion, in a different context, may differ from the choices made in InterOPERA.

For example, depending on the topology, for large PPM, the aggregation might not always be suitable, and it shall be confirmed by the vendor on a case-by-case basis.

Besides, for some functions such as the grid-forming capability, as defined in InterOPERA⁴², aggregation might also not be appropriate. During InterOPERA, if the grid-forming mode is available for the WTs, it shall be assessed through the offline studies, if the full aggregation in HIL is acceptable.

If issues appear in offline, it will be necessary to find a way to address those issues in HIL as well. The level of aggregation in the HIL simulations will be dependent on the type of the issues. If detailed strings are necessary in offline, it might be also necessary to have one detailed string in HIL for quality assurance between offline and HIL.

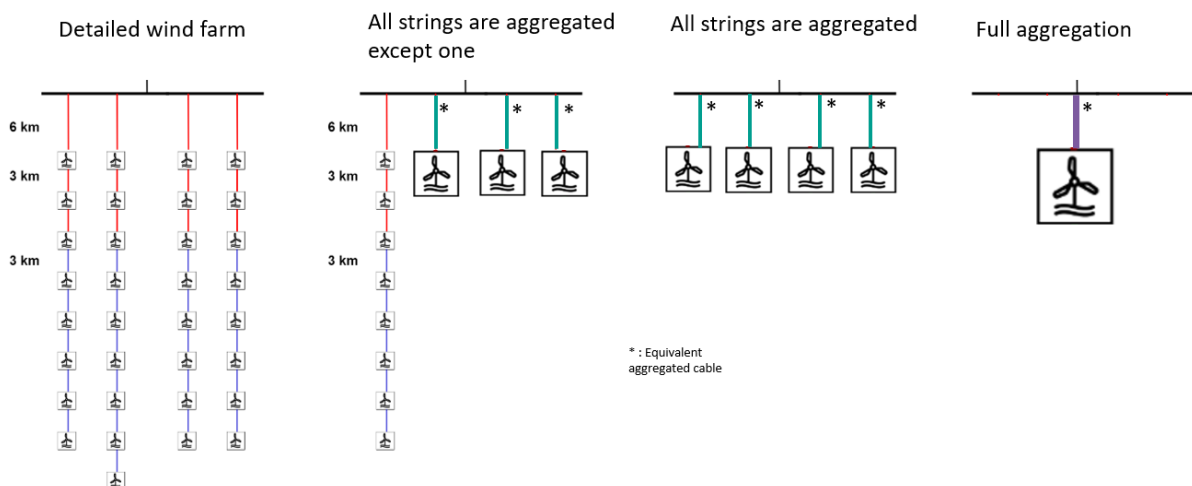

Figure 12: Different options for aggregation

⁴² In InterOPERA D2.2 deliverable, the grid-forming capability is defined as the functional behavior of an HVDC system or DC-connected PPM as a controlled voltage source behind an impedance.

2.4.2 Simulation of the WT behavior

REAL-TIME PPM 4.

Current requirement

In case the vendor proposes to simulate part of the main circuit on an external simulation platform instead of simulating in the lab's RTS:

- The point used for coupling both simulators shall be agreed with the system integrator;
- The coupling method shall be agreed with the system integrator: stability shall be ensured and demonstrated by the vendor;
- The requirements stated in 2.1.3.1 Power circuit modelling apply for the models used on this platform.

Information

Main discussion is on the side of the wind turbine transformer to be chosen for the coupling point. The system integrators have a preference for a coupling point at the secondary side of the transformer, whereas vendors have a preference for a coupling point at the primary side of the transformer.

For the primary side to be accepted, the stability of the system, despite the de-coupling⁴³, shall be demonstrated and explanation on the wind turbine's transformer model are expected, for the system integrators to check if it fulfills the requirements for the interaction studies (for example, the saturation shall be included).

2.4.3 Internal signals to be accessible and recorded

REAL-TIME PPM 5.

Current requirement

At least, the signals defined in OFFLINE PPM 9, coming from the WT control and protection system itself, shall be accessible and recorded, considering REAL-TIME 8.

Maturity level

This is a first proposal and might evolve during the project.

REAL-TIME PPM 6.

Current requirement

⁴³ When the electrical circuit is decoupled, each sub-circuit is solved independently instead of having the whole circuit solved at the same time. If not all the conditions are met to have the right of proceeding that way, this can lead to inaccuracies, which can end up with instabilities in the worst case. This is the reason why it has to be carefully analysed.

At least, the signals defined in OFFLINE PPM 10, coming from the PPC itself, shall be accessible and recorded, considering REAL-TIME 8.

Maturity level

This is a first proposal and might evolve during the project.

2.5 Requirements for hardware in the loop – specific to HVDC converter station

2.5.1 Control and protection required functions

REAL-TIME HVDC 1.

Current requirement

The requirement OFFLINE HVDC 4 also applies for real-time.

2.5.2 Converter valve model

REAL-TIME HVDC 2.

Current requirement

Two types of MMC converter valve model can be proposed by the vendor:

- a detailed one with the individual pulse generated in the control system for each valve, as per the following drawing:

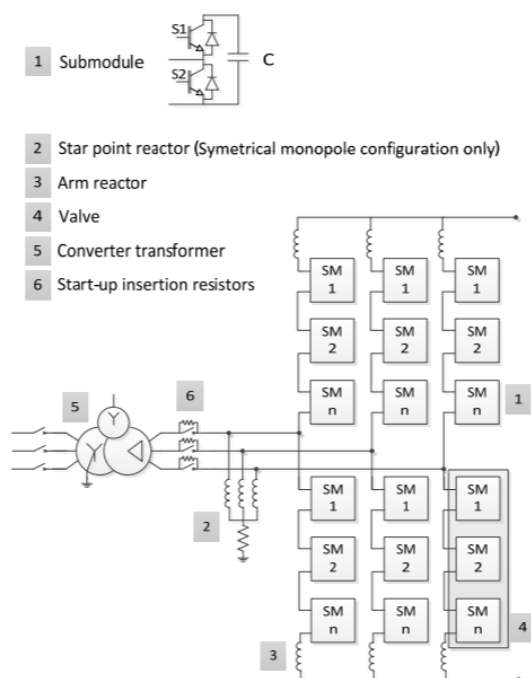

Figure 13: Detailed converter valve model as illustrated in [2]

- an aggregated converter valve model (as described in [5]). Below are two figures extracted from this document to describe briefly this model:

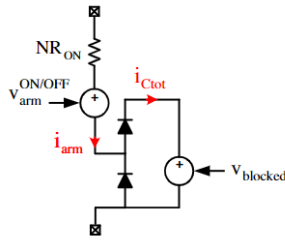

Fig. 2. Equivalent circuit for a MMC half arm.

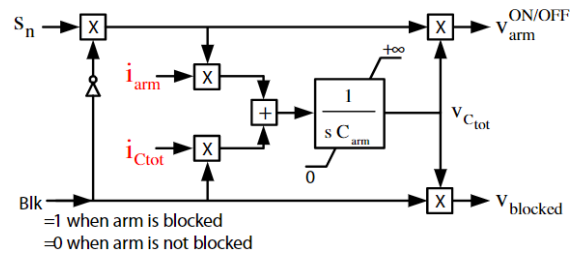

Fig. 3. Equivalent capacitor voltage calculation.

Figure 14: The aggregated converter valve model proposed in [5]

In such a case, the vendor shall provide a documentation to prove the model has been validated. Validation means comparison with detailed valve model implemented in real-time or in offline simulation tools. Limitations of the aggregated model shall be clearly established (type of tests that cannot be performed). The aggregated model shall fit for the purpose of all the tests listed in REAL-TIME 2.

Justification

Based on successful interaction tests performed in previous HVDC projects with the aggregated converter valve model, it is assumed that all the interaction tests to be performed will be written in such a way that they are compatible with the use of aggregated valve model and reversely, it is estimated that this model will have the adequate behavior for performing the targeted real-time interaction tests. This is the reason why this model is proposed. Information on the limitations should be provided to avoid wrong results, a simplification acceptable for the interaction tests might not be acceptable for any test.

However, a vendor shall not choose the aggregated valve mode simply because it is proposed. The system owner shall not be the only one to take this responsibility. The vendor shall confirm that it thinks that this model is appropriate, and that the replica is adapted to this model.

Maturity level

In the future, if it is demonstrated that some interaction tests require a detailed valve model, two options will have to be assessed:

- Force for a detailed valve model in real-time
- Limit these interaction tests to offline, where a detailed valve model would be mandatory, so that only the interaction tests compatible with the aggregated converter valve model are performed in real-time as this decision can highly impact the processing power of the RTS, the hardware to be delivered by the vendor and the major engineering work to redefine and test the updated interface.

REAL-TIME HVDC 3.

Current requirement

A specific documentation for the implementation of the interface between the RTS and the valve controls shall be provided by the vendor.

It shall state which type of converter valve model is used and describe all the relevant information for the interface, included but not limited to: protocol, exchanged signals, packet interval, content and structure of packet.

REAL-TIME HVDC 4.

Current requirement

This interface documentation shall be provided at least one year before the factory system tests of the system.

Justification

This one-year period is due to the time to develop the corresponding interface in the lab's RTS, if it does not exist yet.

2.5.3 Quick restart option

REAL-TIME HVDC 5.

Current requirement

If feasible, tools shall be provided to allow a quick restart of the converter station (for example, to reset the PIR cooling time or to reset any protection lock-out in case of trip)

2.5.4 Internal signals to be accessible and recorded

REAL-TIME HVDC 6.

Current requirement

At least, the signals defined in OFFLINE HVDC 8, coming from the control and protection system itself, shall be accessible and recorded, considering REAL-TIME 8.

Information

It is emphasized that the signals to be recorded in this list are the signals processed by the control and protection system, and not the raw signals coming directly out of the real-time simulator.

For signals to be shared with other parties (if needed for the analysis by these other parties), vendors shall check if the signals are the processed signals or the raw signals. In the latter case, as mentioned in REAL-TIME 8, a solution shall be provided by the vendor, considering that the real-time simulator used by the system integrator cannot be used for those records.

Abbreviations, Acronyms and Definition

	Description
AC	Alternating Current
ATF	Automatic Testing Functionality
C&P	Control and Protection. When C&P is used for hardware, the telecommunication system (switch, routers, etc) is also implicitly included.
DBS	Dynamic Breaker System
DC	Direct Current
DLL	Dynamic-Link Library
EHS	Environmental Health and Safety
EMT	Electromagnetic Transient
FST	Factory System Tests
FRT	Fault Ride Through
HIL	Hardware In the Loop
HVDC	High Voltage Direct Current
HV	High Voltage
MMC	Modular Multilevel Converter
PIR	Pre-insertion Resistor
PPM	Power Park Module
PPC	Power Park Controller
RTS	Real-time simulator
SIL	Software In the Loop
System	A set of HV equipment and/or controller and protections typically designed as a whole, for example an HVDC converter station, a wind turbine
TCP/UDP	Transmission Control Protocol/User Datagram Protocol
TFR	Transient Fault Recorder
TSO	Transmission System Operator

Annex 1

1

2 Excel file model proposed by TU Delft to receive information for the system integrator to prepare the platform where cubicles will be installed

InterOPERA infrastructure inventory		IEPG Intelligent Electrical Power Grids	
last update: dd: 2022-08-01 (RK)			
General	Vendor name		
Description			
housing			
size required			how much space is preferable required for the hardware to be installed?
entrance opening required			how wide/high needs the entrance opening to be to be able to move the equipment in?
security			are there any restrictions with security to the equipment?
other...			feel free to add any additional requirement you think is important for the project
facilities			
cooling			is cooling required, if so how?
heating			is heating required, if so how?
total peak power consumption			what is the maximum total electrical power?
networking (for equipment and auxiliaries)			are there any specific requirements for the networking, max delay times, specific protocols used etc?
time reference (type, protocol)			is there a requirement for a time reference, what kind and which protocol(s)?
floor			are there specific requirements to the floor?
other...			feel free to add any additional requirement you think is important for the project
Equipment			
Description			
Unit(s)			
cubicle/cabinet count			how many cubicles/cabinets does total system incorporates?
cubicle size (WxDxH [mm])			what is the size of (each) cabinet?
weight per cubicle [kg]			what is the weight of (each) cabinet?
way of installation (feet, wheels fixed)			how will the cabinets be installed, on feet, wheels or otherwise?
way of connecting cabling			how do the required cable enter the cabinets (top, bottom, sides)?
environmental conditions (storage)			what are the environmental storage conditions for the equipment?
environmental conditions (operations)			what are the environmental operating conditions for the equipment?
power requirements			what are the power requirement per cubicle/cabinet and the total?
max connection distance to RTDS			is there a specific maximum connection length for any (FO) cable other then specified by RTDS?
other...			feel free to add any additional requirement you think is important for the project
Is separate room needed?			

3

References

- [1] FINAL REPORT FROM THE EXPERT GROUP FOR INTERACTION STUDIES AND SIMULATION MODELS (EG ISSM) AT ENTSO-E LEVEL
[HTTPS://EEPUBLICDOWNLOADS.BLOB.CORE.WINDOWS.NET/PUBLIC-CDN-CONTAINER/CLEAN-DOCUMENTS/NETWORK%20CODES%20DOCUMENTS/GC%20ESC/ISSM/EG_ISSM_FINAL_REPORT_211001.PDF](https://eepublicdownloads.blob.core.windows.net/public-cdn-container/clean-documents/network%20codes%20documents/gc%20esc/issm/eg_issm_final_report_211001.pdf)
- [2] CIGRE WORKING GROUP B4-57 PAPER: GUIDE FOR THE DEVELOPMENT OF MODELS FOR HVDC CONVERTERS IN A HVDC GRID, CIGRE TECHNICAL BROCHURE 604, DECEMBER 2014
- [3] CIGRE WORKING GROUP CC02: GUIDE FOR ASSESSING THE NETWORK HARMONIC IMPEDANCE, ELECTRA N° 167, AUGUST 1996
- [4] IEC 62747 TERMINOLOGY FOR VOLTAGE-SOURCED CONVERTERS (VSC) FOR HIGH-VOLTAGE DIRECT CURRENT (HVDC) SYSTEMS
- [5] SETUP AND PERFORMANCES OF THE REAL-TIME SIMULATION PLATFORM CONNECTED TO THE INELFE CONTROL SYSTEM, S. DENNETIERE, H. SAAD, B. CLERC, J. MAHSEREDJIAN, ELECTRIC POWER SYSTEMS RESEARCH, 138 (2016) 180–187
- [6] ENTSO-E STANDARDIZED CONTROL INTERFACE FOR HVDC SIL/HIL CONFORMITY TESTS, APRIL 2020, https://eepublicdownloads.entsoe.eu/clean-documents/Publications/Position%20papers%20and%20reports/ENTSO-E_Standardized_control_interface_update_2020_07_15_.pdf
- [7] CIGRE WORKING GROUP B4-67 PAPER: AC SIDE HARMONICS AND APPROPRIATE HARMONIC LIMITS FOR VSC HVDC, CIGRE TECHNICAL BROCHURE 754, FEBRUARY 2019
- [8] JOINT WORKING GROUP CIGRE B4.82 / IEEE: GUIDELINES FOR USE OF REAL-CODE IN EMT MODELS FOR HVDC, FACTS AND INVERTER BASED GENERATORS IN POWER SYSTEMS ANALYSIS, CIGRE TECHNICAL BROCHURE 958, FEBRUARY 2025
- [9] GUIDANCE NOTES FOR ELECTRO-MAGNETIC TRANSIENT (EMT) MODELS, NATIONAL GRID ESO, JANUARY 2023
<https://www.nationalgrideso.com/document/275661/download>
- [10] PLANNING CODE, NATIONAL GRID ESO, MARCH 2024
<https://www.nationalgrideso.com/document/287041/download>
(this document is not applicable yet and under evaluation by a review panel)
- [11] INTEROPERA, T2.1 GROUP : D2.1 FUNCTIONAL REQUIREMENTS FOR HVDC GRID SYSTEMS AND SUBSYSTEMS, 2024